

N°DIS.: T98_801_OPUSCOLO
N°DIS.: T165_800_OPUSCOLO
N°DIS.: T181_800

data: 05/08/2020 rev.02

VIDEO MONTAGGIO
ASSEMBLY VIDEO
INSTRUCTIONS
VIDEO DE MONTAGE
EINBAU VIDEOEINLEITUNGEN
VIDEO MONTAJE
видео-инструкции сборки

CRUZ 01.80 (120/170x80)
01.87 (160/210/260x90)
20.27 (190/240/290x100)

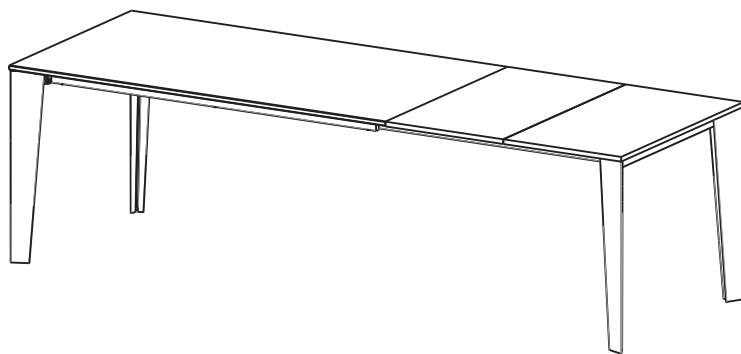

PAG. 3

CRUZ 20.26 (140/180/220x90)

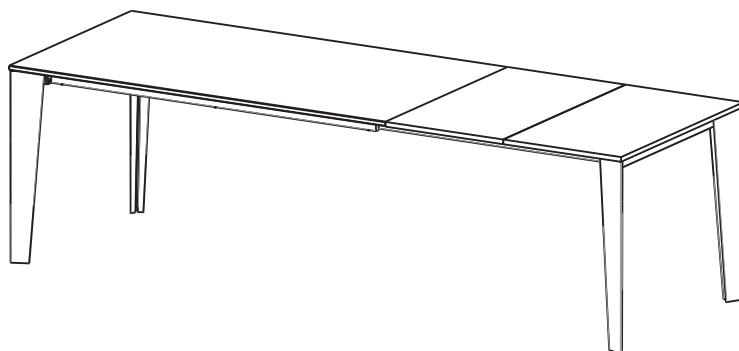

PAG. 9

CRUZ XXL 20.69 (140/193/246/299x90)

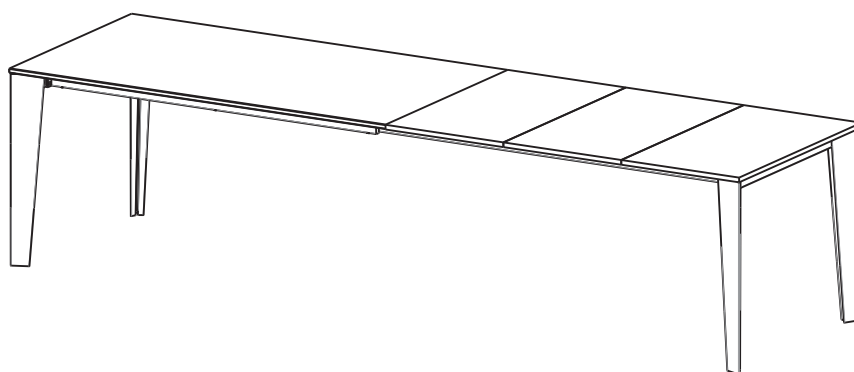

PAG.15

MADE IN ITALY



B 4 LIVING Spa

Via Direttissima del Conero, 51
60021 Camerano (AN) - I
ITALY

Tel. +39.071.7300032

www.bontempi.it

EXPORT

Tel. +39.071.7304112

www.bontempicasa.com

BONTEMPI
CASA

Grazie per aver scelto BONTEMPI CASA.
Thanks for choosing BONTEMPI CASA.
Merci d'avoir choisi BONTEMPI CASA.
Danke für Ihre Wahl an BONTEMPI CASA.
Gracias por elegir BONTEMPI CASA.
Спасибо, что вы выбрали BONTEMPI CASA.



ATTENZIONE:

Il corretto funzionamento dell'articolo è garantito solo con l'uso appropriato delle seguenti istruzioni, pertanto è necessario conservarle.

Istruzioni di montaggio ,da consegnare al consumatore finale.

Per uso e manutenzione, seguire le indicazioni riportate nel cartellino prodotto

WARNING:

The item operates properly only if you strictly follow these instructions.
Please keep it apart.

Assembly ,instructions for the end user.

For use and maintenance, follow the instructions on the product label

ATTENTION:

Le respect des instructions d'utilisation et un usage approprié garantissent le fonctionnement correct de l'article. Il est donc nécessaire de les lire et de les conserver.

Instruction de montage, à remettre au consommateur final.

Pour l'usage et l'entretien, suivez les instructions sur l'étiquette du produit.

ACHTUNG:

Die korrekte Ausgestaltung des Artikels ist nur bei der richtige Verwendung der Anleitungen gewährleistet, deshalb diese gehalten.

Montageanleitung an den Endverbraucher auszuhändigen.

Für Reinigung und Pflege folgen Sie die Anweisungen auf dem Produktetikett.

ATENCION:

El correcto funcionamiento del artículo está garantizado solamente con el uso apropiado de las instrucciones adjuntas, por ello es necesario conservarlas.

Las instrucciones de montaje,deben ser entregadas al consumidor final.

Para uso y mantenimiento, siga las instrucciones en la etiqueta del producto

ВНИМАНИЕ:

Правильное функционирование данного артикула гарантировано только при использовании следующей инструкции, поэтому ее необходимо сохранять.

Инструкции монтажа, обслуживания для передачи конечному потребителю. По уходу и эксплуатации соблюдайте инструкции, указанные на этикетке изделия.

CRUZ

01.80 (120/170x80)

01.87 (160/210/260x90)

20.27 (190/240/290x100)

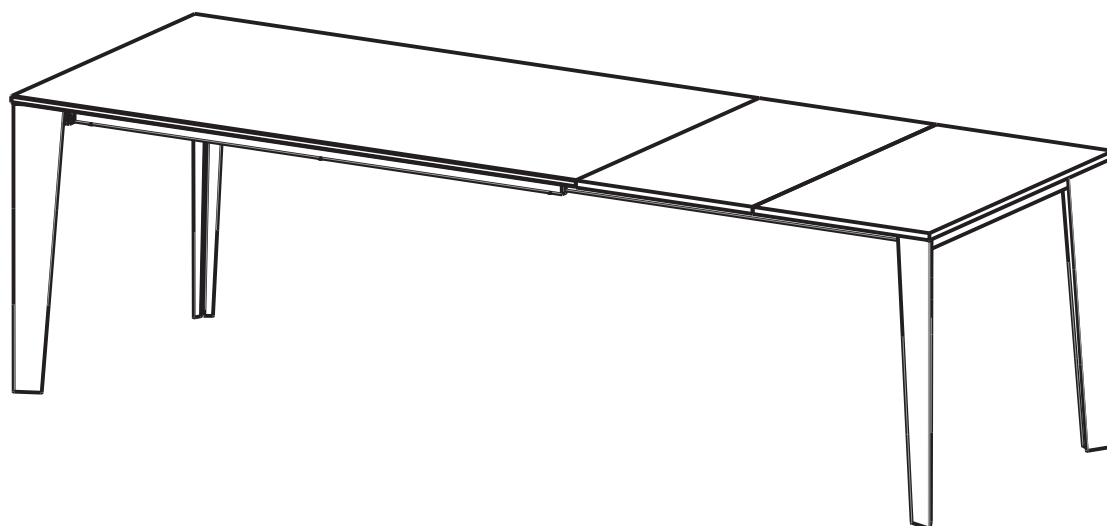

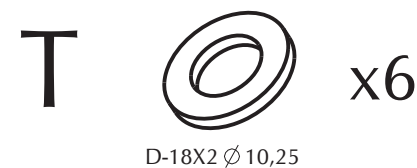
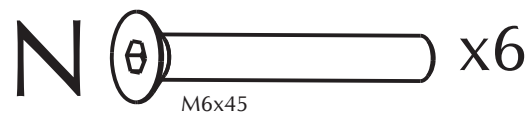
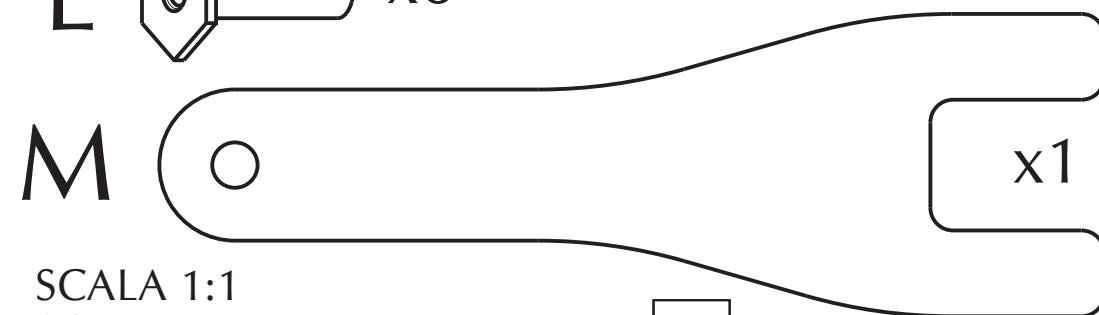
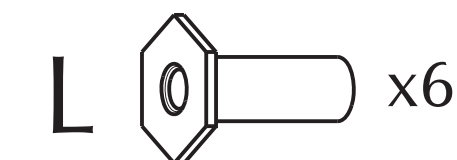
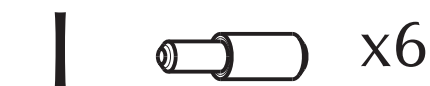
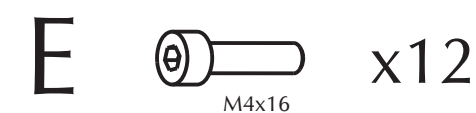
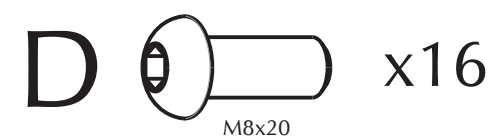
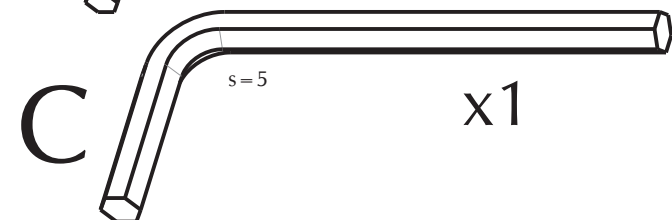
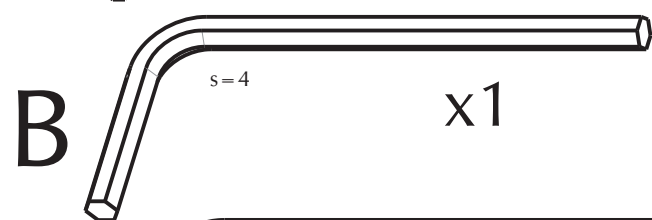
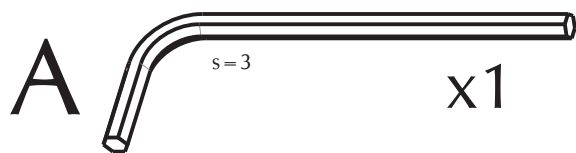

SCALA 1:1
SCALE 1:1

1

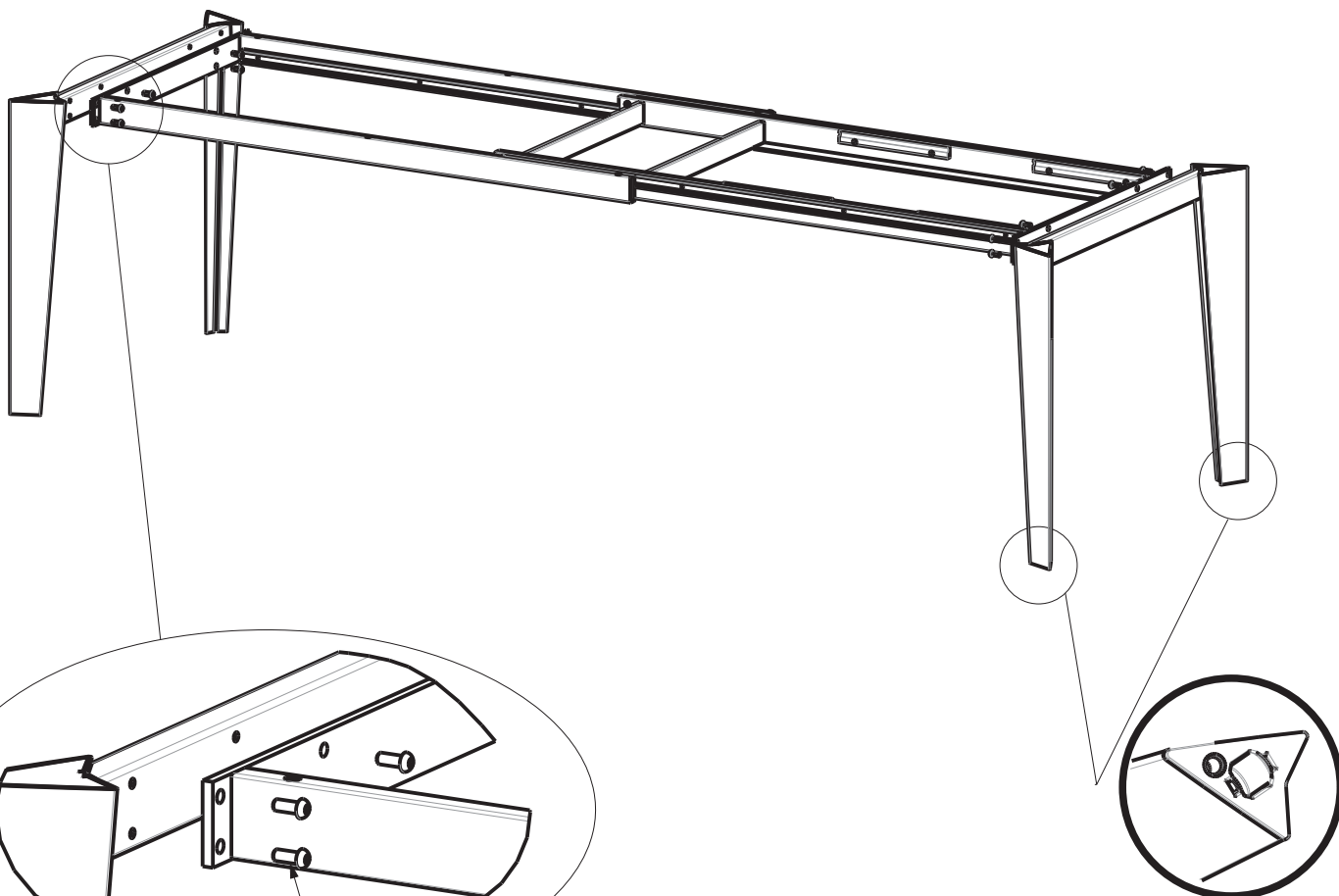

D
x8 art.01.80
x16 art.01.87-20.27

- (I) GAMBA LATO PROLUNGA
- (GB) EXTENSION SIDE LEG
- (D) FUß KANTE DER VERLÄNGERUNG
- (F) PIED CÔTÉ ALLONGE
- (E) PATA LADO PROLONGACIÓN
- (RU) НОГА СО СТОРОНЫ УДЛИНИТЕЛЯ

2A

- Ⓘ PIANO IN CRISTALLO / SUPERCERAMICA / SUPERMARMO / SUPERCEMENTO
- ⒸⒹ GLASS TOP / TOP IN SUPERCERAMIC / TOP IN SUPERMARBLE / TOP IN SUPERCONCRETE
- Ⓓ GLASPLATTE / PLATTE SUPERKERAMIK / PLATTE SUPERMARMOR / PLATTE SUPERZEMENT
- Ⓕ PLATEAUX EN VERRE / SUPERCERAMICA / SUPERMARBRE / SUPERBETON
- Ⓔ SOBRE EN CRISTAL / SUPERCERAMICA / SUPERMÁRMOL / SUPERCEMENTO
- ⓇⓈ СТОЛЕШНИЦА ИЗ СТЕКЛА / СУПЕРКЕРАМИКИ / СУПЕРМАРМОРА / СУПЕРЦЕМЕНТА

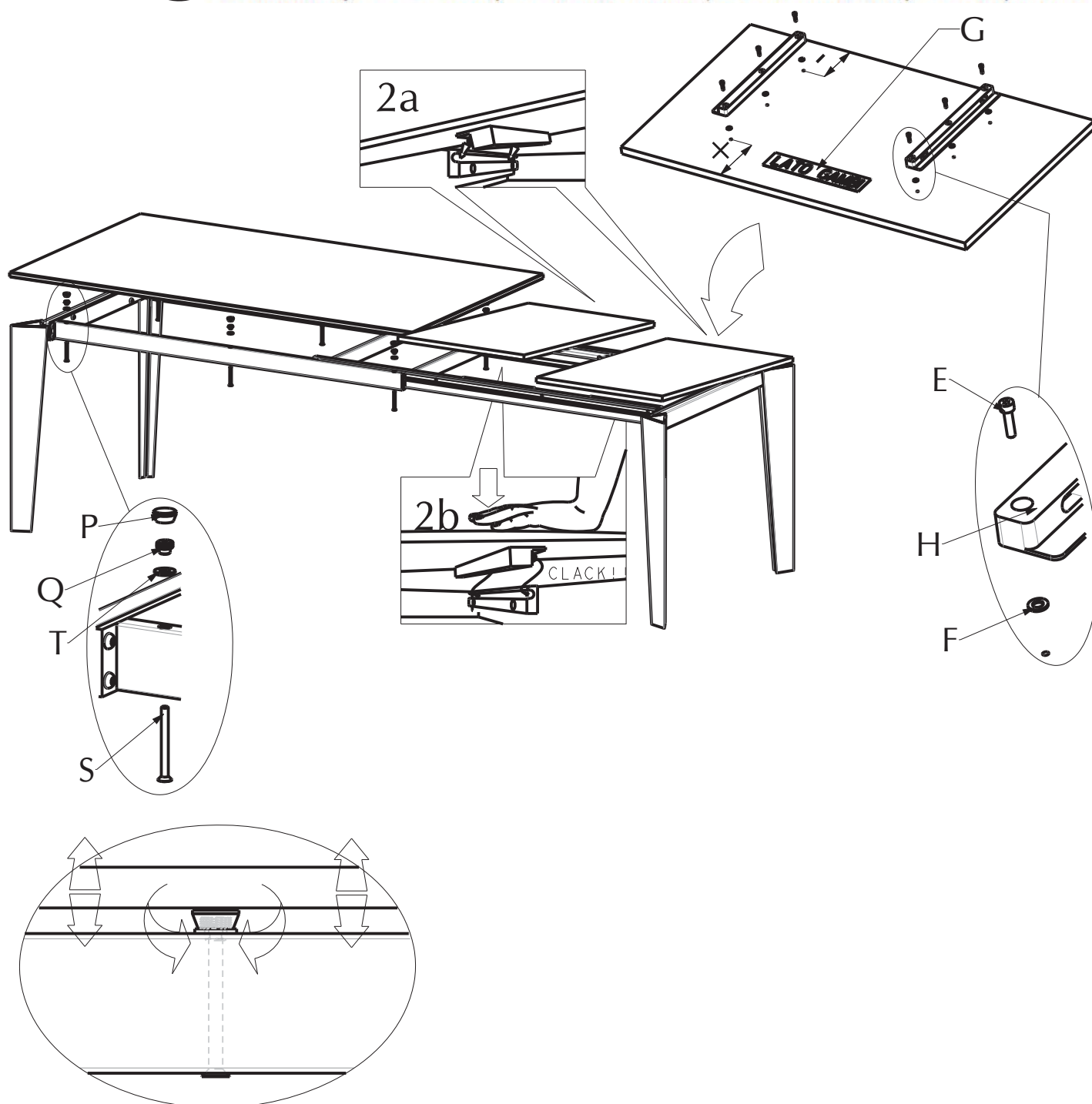

- Ⓘ Ruotare il particolare (P) per regolare planarità e altezza del top
- ⒸⒹ Turn part (P) to adjust the height and flatness top
- Ⓓ Drehen Sie Teil (P), um die Höhe und Ebenheit oben anpassen
- Ⓕ Tourner le particulier (P) pour ajuster la hauteur et de planéité des plateau
- Ⓔ Girar el particular (P) para ajustar la altura y la parte superior planitud de tapa
- ⓇⓈ Вращать деталь (P) для регулирования ровности и высоты столешницы

2B

- Ⓡ I PIANI IMPIALLACCIATI / MELAMINICO / FENIX / UNICOLOR
- Ⓢ GB VENEERED / MELAMINE / FENIX / UNICOLOR TOPS
- Ⓣ D PLATTE FURNIERT / MELAMIN / FENIX / UNICOLOR
- Ⓤ F PLATEAUX EN BOIS PLAQUÉ / MELAMINE / FENIX / UNICOLOR
- Ⓥ E SOBRES EN CHAPEADOS / MELAMINADO / FENIX / UNICOLOR
- Ⓦ RU СТОЛЕШНИЦЫ ИЗ ШПОНА / МЕЛАМИНА / ФЕНИКСА / УНИКОЛОРА

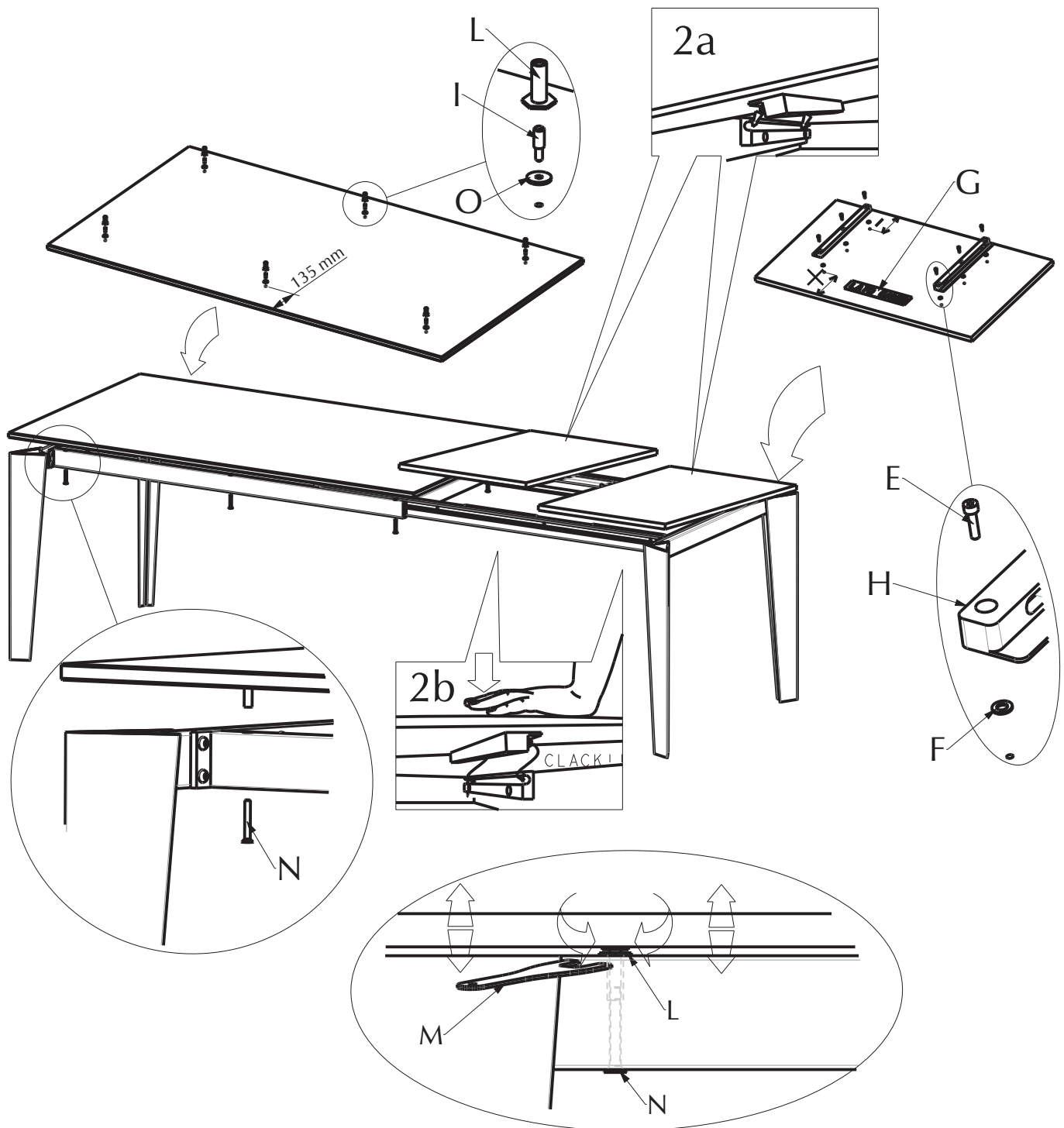

- Ⓡ I A tavolo aperto posizionare il piano sul telaio come in figura. Regolarlo in altezza avvitando e svitando le viti (L-N)
- Ⓢ GB When table is open position the top as shown in the figure. Adjust it in height by screwing and unscrewing the screws (L-N)
- Ⓣ D Wenn Tisch ausgezogen ist die Platte auf den Rahmen positionieren wie auf dem Bild. Platte in der Höhe durch an- und abschrauben einstellen (L-N)
- Ⓤ F A table ouverte positionner le plateau comme dans la figure. Régler en hauteur en vissant et dévissant les vis (L-N)
- Ⓥ E Con la mesa abierta colocar el sobre sobre la estructura como en la figura. Regularlo en altura enroscando y desenroscando los tornillos (L-N)
- Ⓦ RU На раскрытом столе устанавливать столешницу на раму, как показано на рисунке. Регулировать по высоте, завинчивая и развинчивая винты (L-N)

3

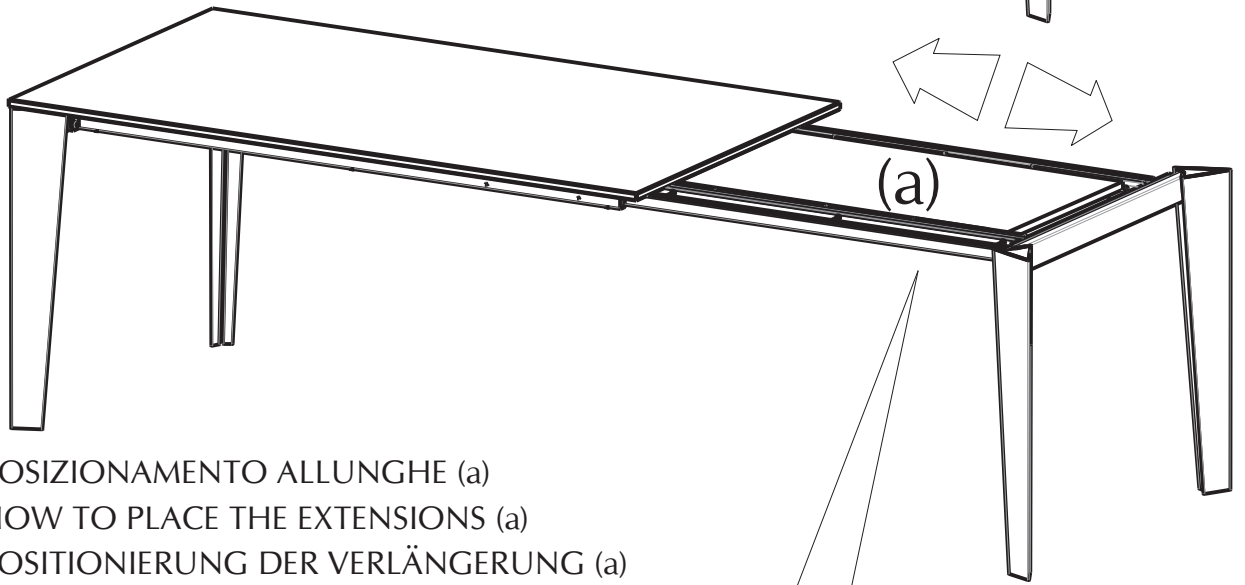
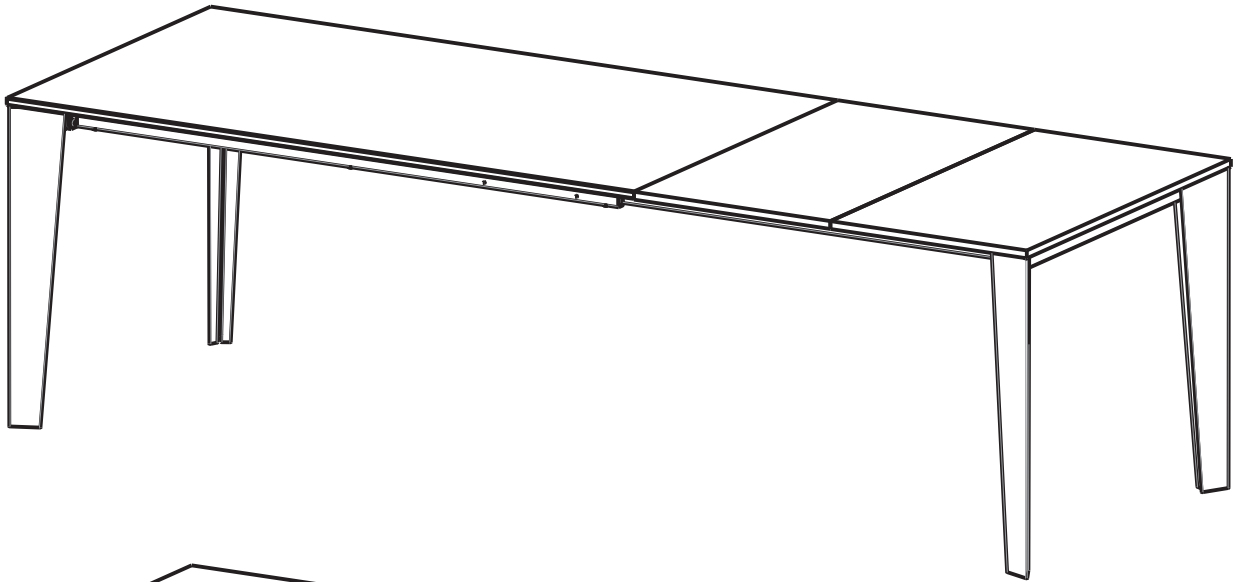

- ① POSIZIONAMENTO ALLUNGHE (a)
- ② HOW TO PLACE THE EXTENSIONS (a)
- ③ POSITIONIERUNG DER VERLÄNGERUNG (a)
- ④ EMBLACEMENT DES ALLONGES (a)
- ⑤ COLOCACIÓN DE LAS PROLONGACIONES (a)
- ⑥ УСТАНОВКА УДЛИНИТЕЛЕЙ (a)

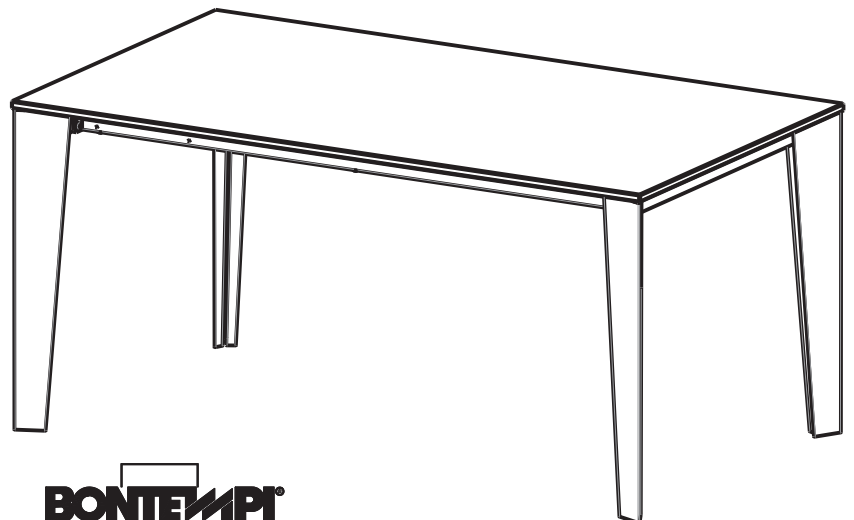
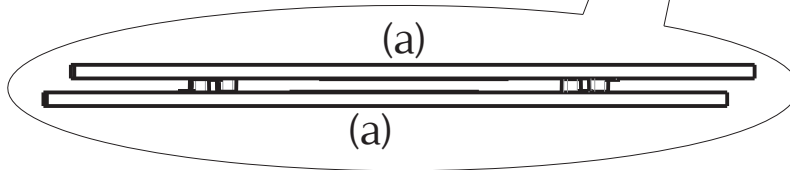

CRUZ

20.26 (140/180/220x90)

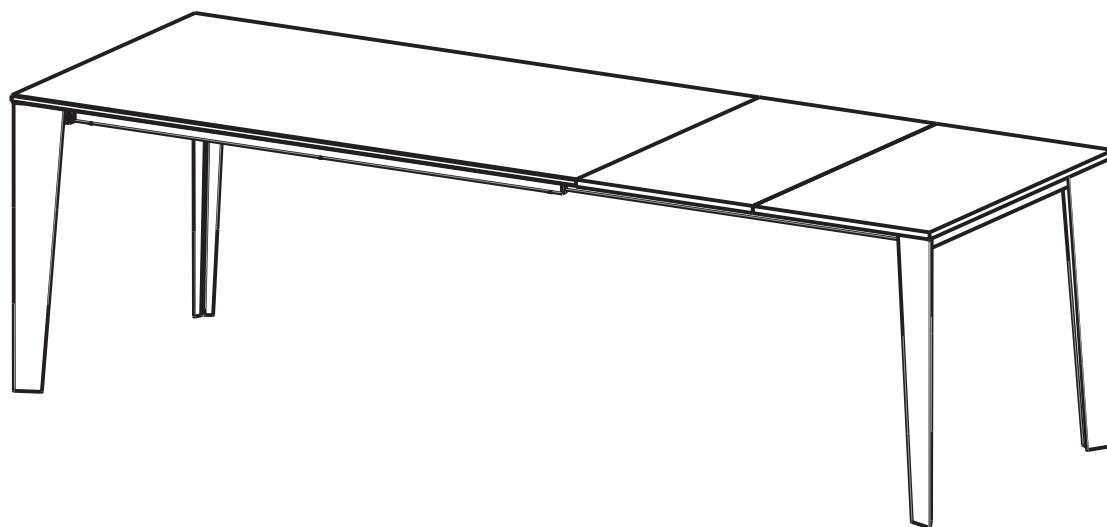

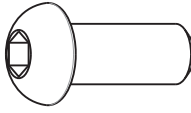
A  x16
M8x20

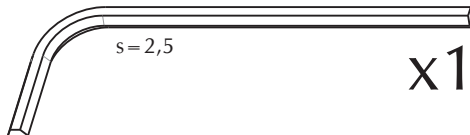
 s=2,5 x1

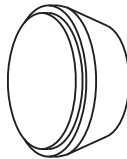
B  x6

 s=3 x1

C  x6

 s=4 x1

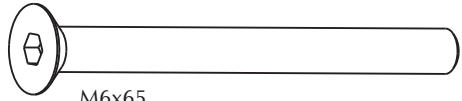
D  x6
M6x65

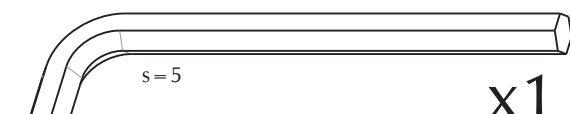
 s=5 x1

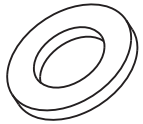
E  x6
D-18X2 \varnothing 10,25

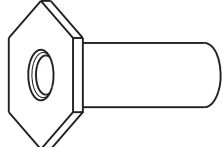
F  x6

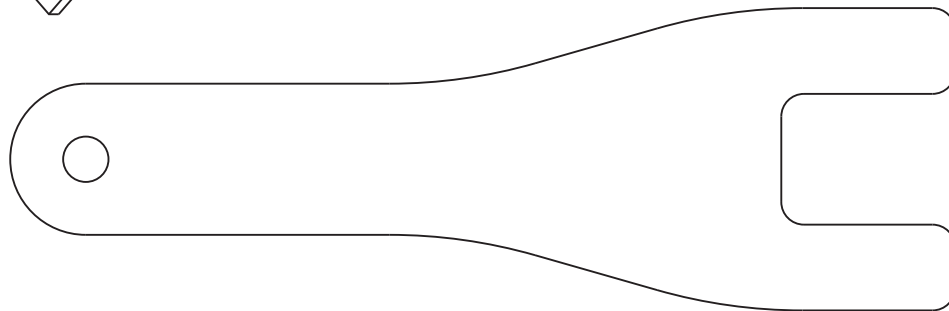
G 

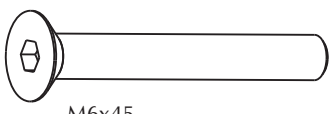
H  x6
M6x45

L  x6

N  x4

M  x8
D15X1,5 \varnothing 5

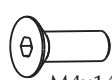
O  x8
M4x14

SCALA 1:1
SCALE 1:1

1

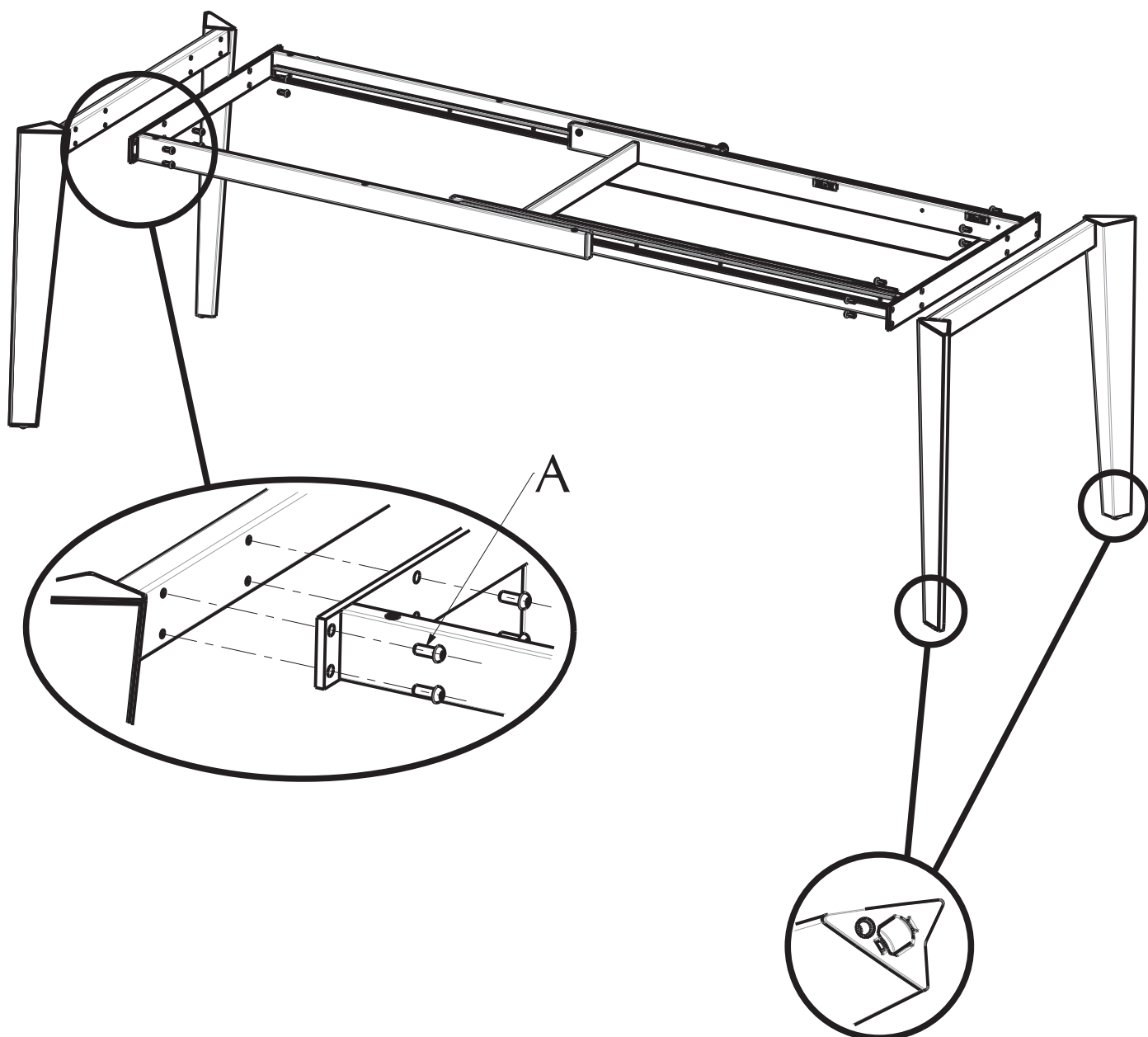

- (I) GAMBA LATO PROLUNGA
- (GB) EXTENSION SIDE LEG
- (D) FUß KANTE DER VERLÄNGERUNG
- (F) PIED CÔTÉ ALLONGE
- (E) PATA LADO PROLONGACIÓN
- (RU) НОГА СО СТОРОНЫ УДЛИНИТЕЛЯ

2A

- Ⓘ PIANO IN CRISTALLO / SUPERCERAMICA / SUPERMARMO / SUPERCEMENTO
- Ⓒ GB GLASS TOP / TOP IN SUPERCERAMIC / TOP IN SUPERMARBLE / TOP IN SUPERCONCRETE
- Ⓓ GLASPLATTE / PLATTE SUPERKERAMIK / PLATTE SUPERMARMOR / PLATTE SUPERZEMENT
- Ⓕ PLATEAUX EN VERRE / SUPERCERAMICA / SUPERMARBRE / SUPERBETON
- Ⓖ SOBRE EN CRISTAL / SUPERCERAMICA / SUPERMÁRMOL / SUPERCEMENTO
- Ⓡ RU СТОЛЕШНИЦА ИЗ СТЕКЛА / СУПЕРКЕРАМИКИ / СУПЕРМРАМОРА / СУПЕРЦЕМЕНТА

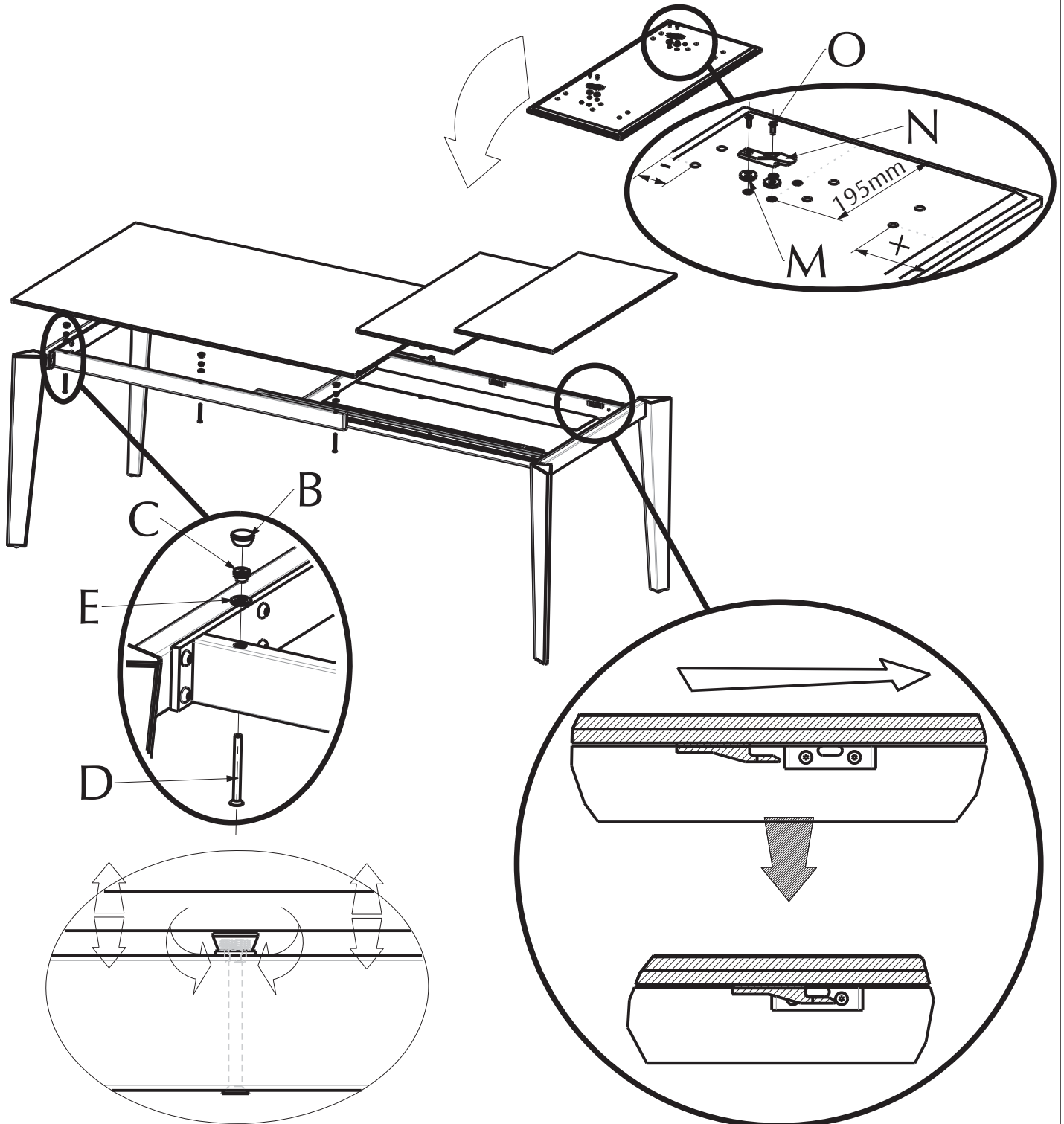

- Ⓘ Ruotare il particolare (B) per regolare planarità e altezza del top
- Ⓒ GB Turn part (B) to adjust the heightband flatness top
- Ⓓ Drehen Sie Teil (B), um die Höhe und Ebenheit oben anpassen
- Ⓕ Tourner le particulier (B) pour ajuster la hauteur et de planéité des plateau
- Ⓖ Girar el particular (B) para ajustar la altura y la parte superior planitud de tapa
- Ⓡ RU Вращать деталь (B) для регулирования ровности и высоты столешницы

2B

- Ⓛ PIANI IMPIALLACCIATI / MELAMINICO / FENIX / UNICOLOR
- ⓖB VENEERED / MELAMINE / FENIX / UNICOLOR TOPS
- ⓓ PLATTE FURNIERT / MELAMIN / FENIX / UNICOLOR
- ⓕ PLATEAUX EN BOIS PLAQUÈ / MELAMINE / FENIX / UNICOLOR
- ⓔ SOBRES EN CHAPEADOS / MELAMINADO / FENIX / UNICOLOR
- ⓇU СТОЛЕШНИЦЫ ИЗ ШПОНА / МЕЛАМИНА / ФЕНИКСА / УНИКОЛОРА

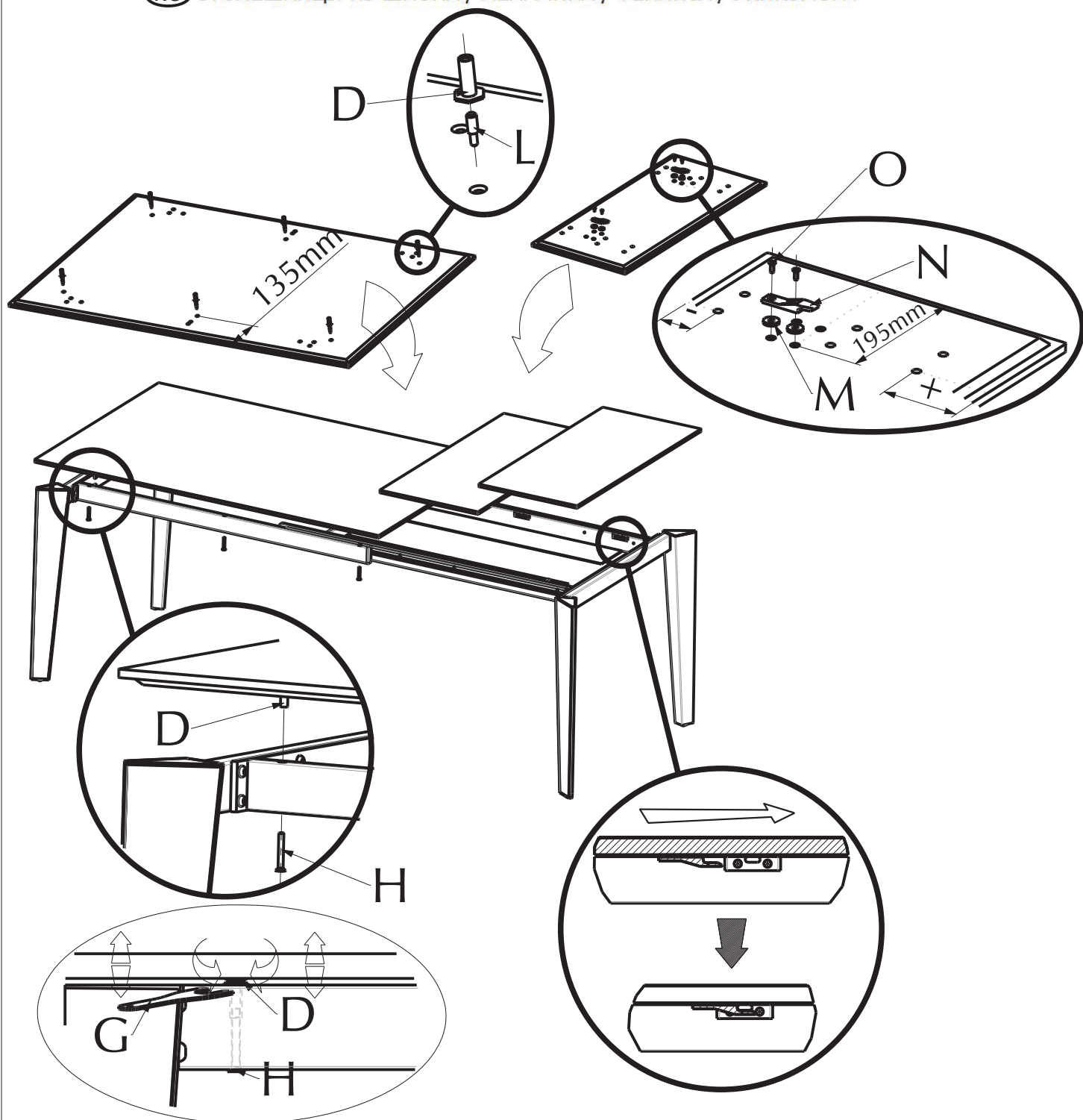

- Ⓛ A tavolo aperto posizionare il piano sul telaio come in figura. Regolarlo in altezza avvitando e svitando le viti (F-H)
- ⓖB When table is open position the top as shown in the figure. Adjust it in height by screwing and unscrewing the screws (F-H)
- ⓓ Wenn Tisch ausgezogen ist die Platte auf den Rahmen positionieren wie auf dem Bild. Platte in der Höhe durch an- und abschrauben einstellen (F-H)
- ⓕ A table ouverte positionner le plateau comme dans la figure. Régler en hauteur en vissant et dévissant les vis (F-H)
- ⓔ Con la mesa abierta colocar el sobre sobre la estructura como en la figura. Regularlo en altura enroscando y desenroscando los tornillos (F-H)
- ⓇU На раскрытом столе устанавливать столешницу на раму, как показано на рисунке. Регулировать по высоте, завинчивая и развинчивая винты (F-H)

3

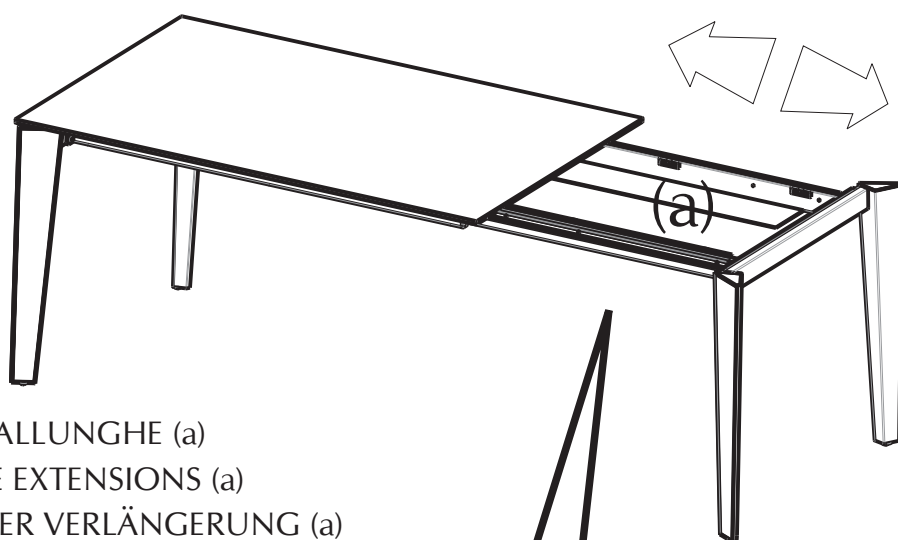
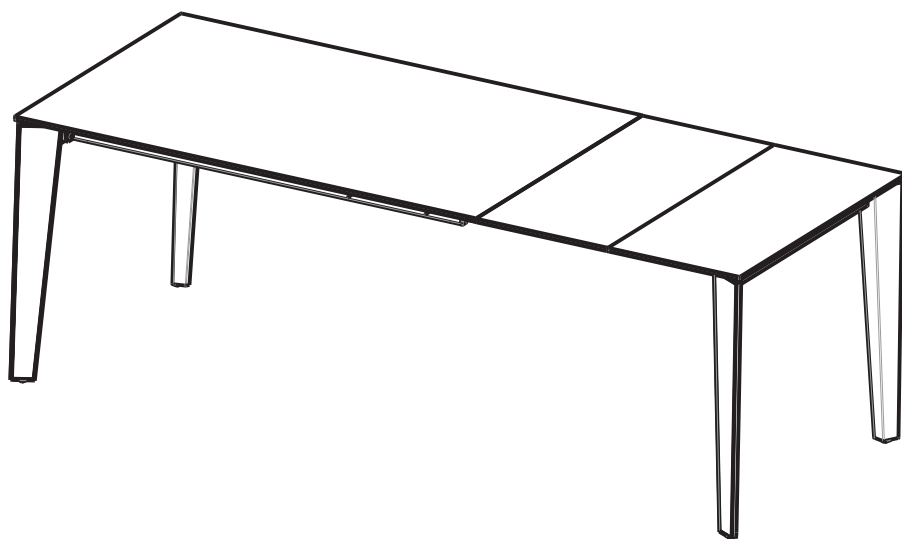

- Ⓘ POSIZIONAMENTO ALLUNGHE (a)
- Ⓒ HOW TO PLACE THE EXTENSIONS (a)
- Ⓓ POSITIONIERUNG DER VERLÄNGERUNG (a)
- Ⓕ EMBLACEMENT DES ALLONGES (a)
- Ⓔ COLOCACIÓN DE LAS PROLONGACIONES (a)
- Ⓡ УСТАНОВКА УДЛИНИТЕЛЕЙ (a)

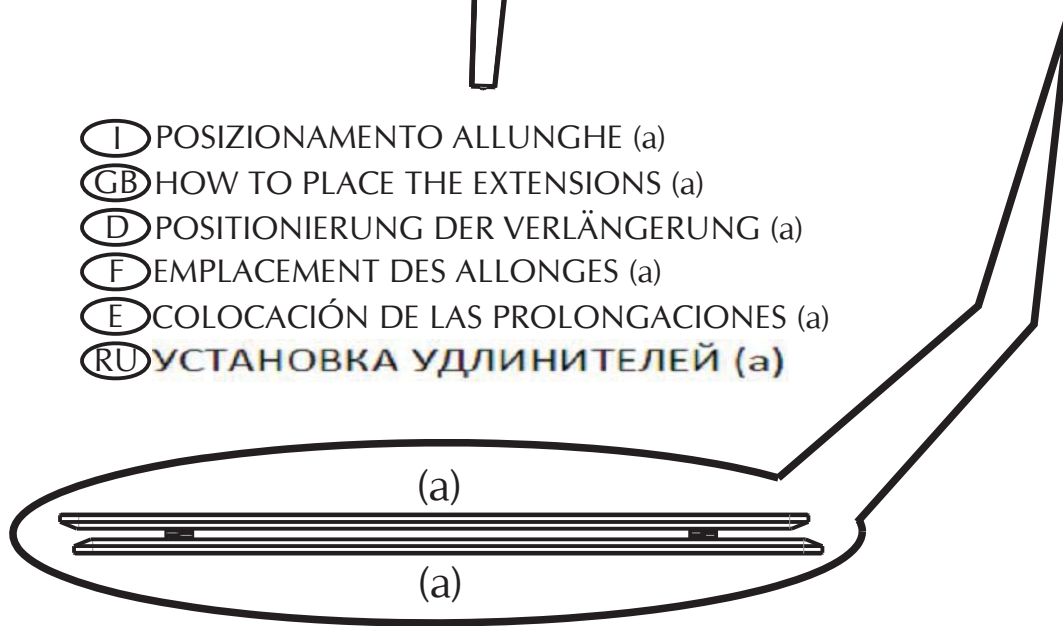

CRUZ XXL

20.69 (140/193/246/299x90)

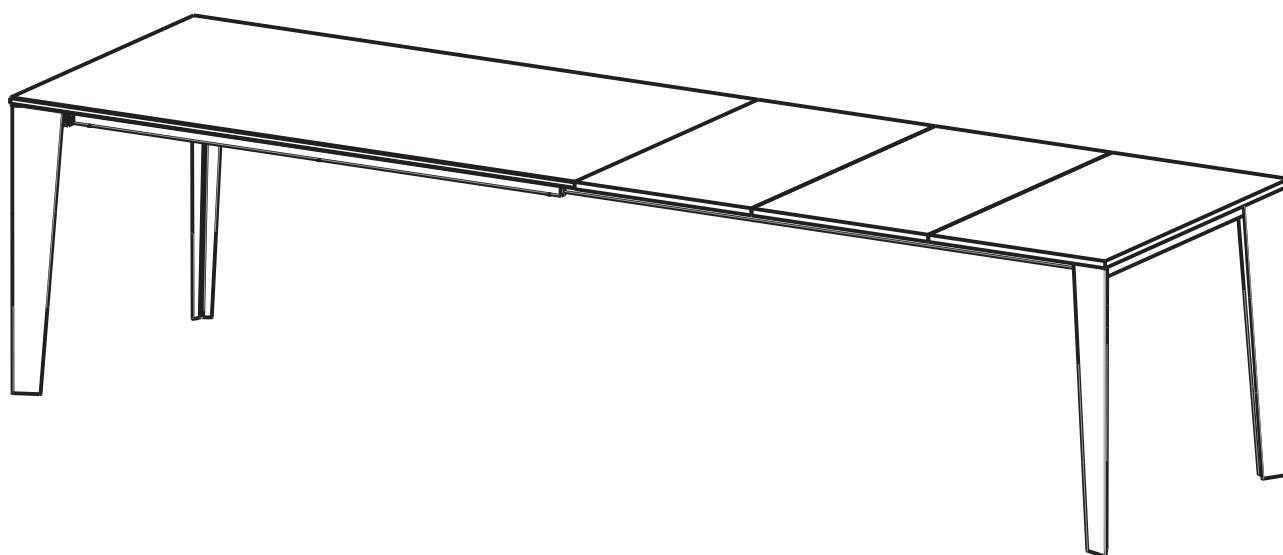

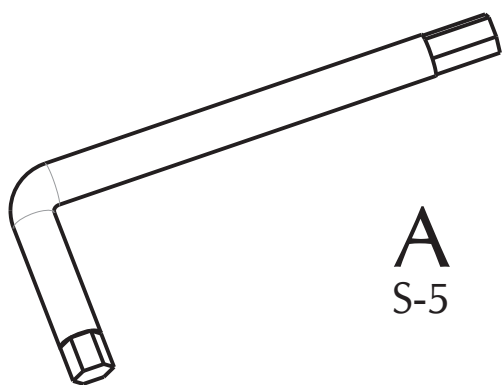

A
S-5

1x

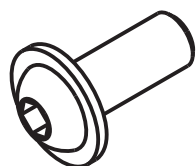

B
M8x20

16x

PAG. 18

- (I) PIANO IN CRISTALLO / SUPERCERAMICA / SUPERMARMO / SUPERCEMENTO
(GB) GLASS TOP / TOP IN SUPERCERAMIC / TOP IN SUPERMARBLE / TOP IN SUPERCONCRETE
(D) GLASPLATTE / PLATTE SUPERKERAMIK / PLATTE SUPERMARMOR / PLATTE SUPERZEMENT
(F) PLATEAUX EN VERRE / SUPERCERAMICA / SUPERMARBRE / SUPERBETON
(E) SOBRE EN CRISTAL / SUPERCERAMICA / SUPERMÁRMOL / SUPERCEMENTO
(RU) СТОЛЕШНИЦА ИЗ СТЕКЛА / СУПЕРКЕРАМИКИ / СУПЕРМАРМОРА / СУПЕРЦЕМЕНТА

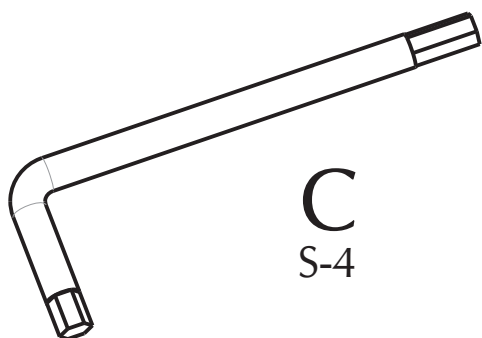

C
S-4

1x

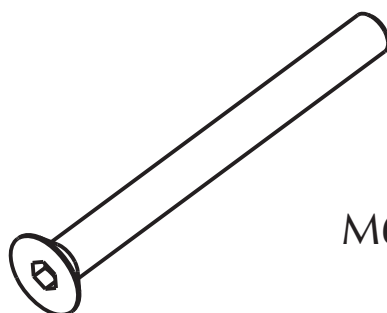

D
M6x65

6x



R
Ø18X2
F.10,25

6x



E
H 8MM

6x



F
H 10MM

6x

PAG. 20

- (I) PIANI IMPIALLACCIATI / MELAMINICO / FENIX / UNICOLOR
- (GB) VENEERED / MELAMINE / FENIX / UNICOLOR TOPS
- (D) PLATTE FURNIERT / MELAMIN / FENIX / UNICOLOR
- (F) PLATEAUX EN BOIS PLAQUE' / MELAMINE / FENIX / UNICOLOR
- (E) SOBRES EN CHAPEADOS / MELAMINADO / FENIX / UNICOLOR
- (RU) СТОЛЕШНИЦЫ ИЗ ШПОНА / МЕЛАМИНА / ФЕНИКСА / УНИКОЛОРА

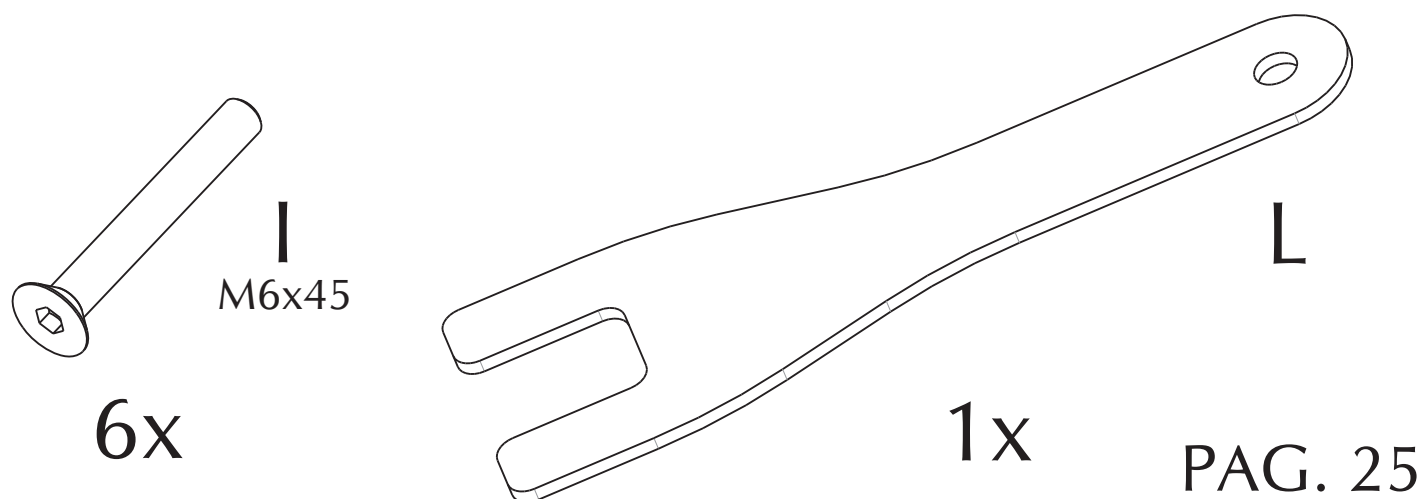
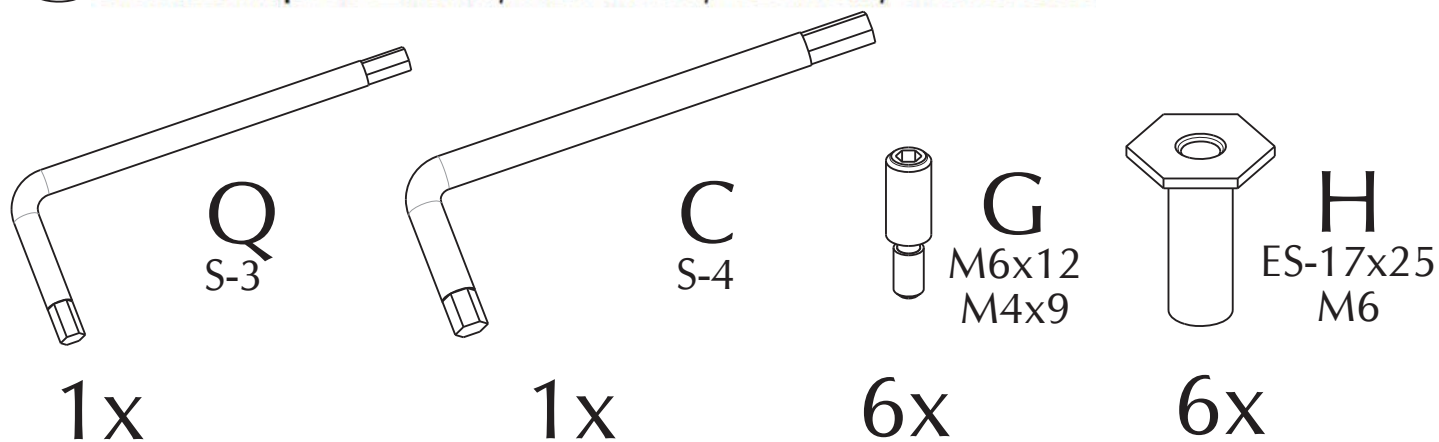

- (I) ALLUNGHE
- (GB) EXTENSIONS
- (D) VERLÄNGERUNG
- (F) ALLONGES
- (E) PROLONGACIONES
- (RU) УДЛИНИТЕЛИ

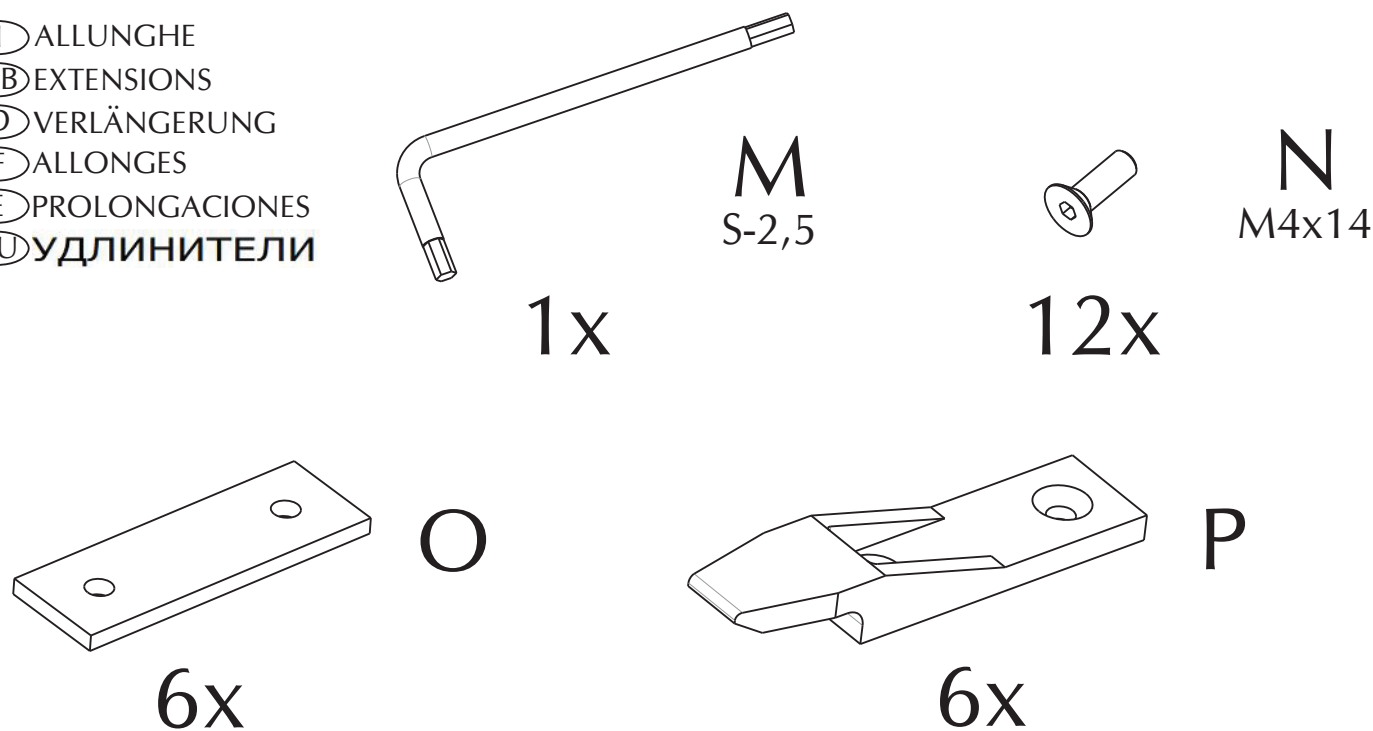

1

- Ⓡ APRIRE IL TELAIO
- ⒸB OPEN THE FRAME
- Ⓓ GESTELL ÖFFNEN
- Ⓕ OUVRIR LE CHÂSSIS
- Ⓔ ABRIR LA ESTRUCTURA
- ⓇU ОТКРЫТЬ РАМУ

NO

OK

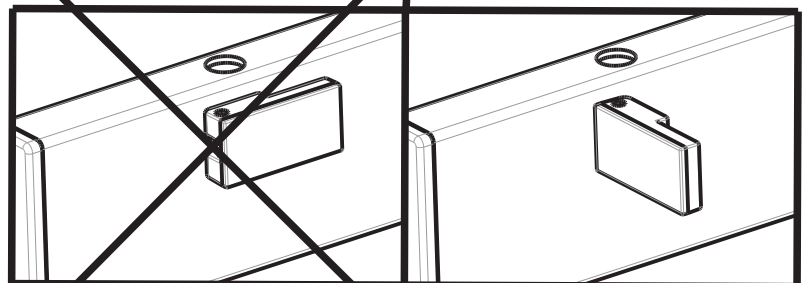
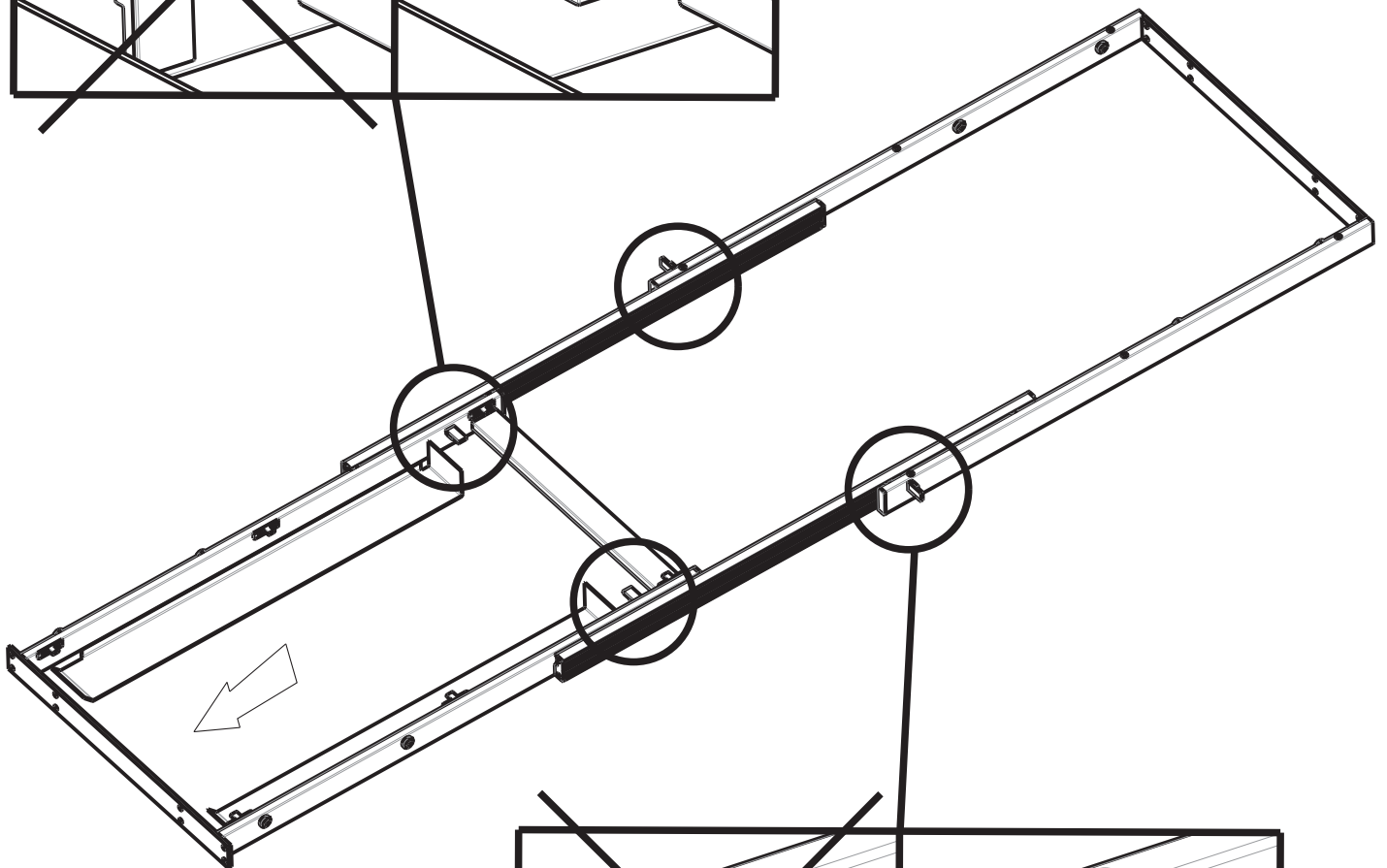
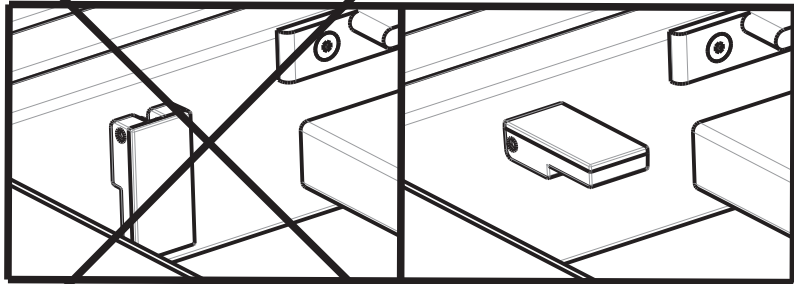

NO

OK

2

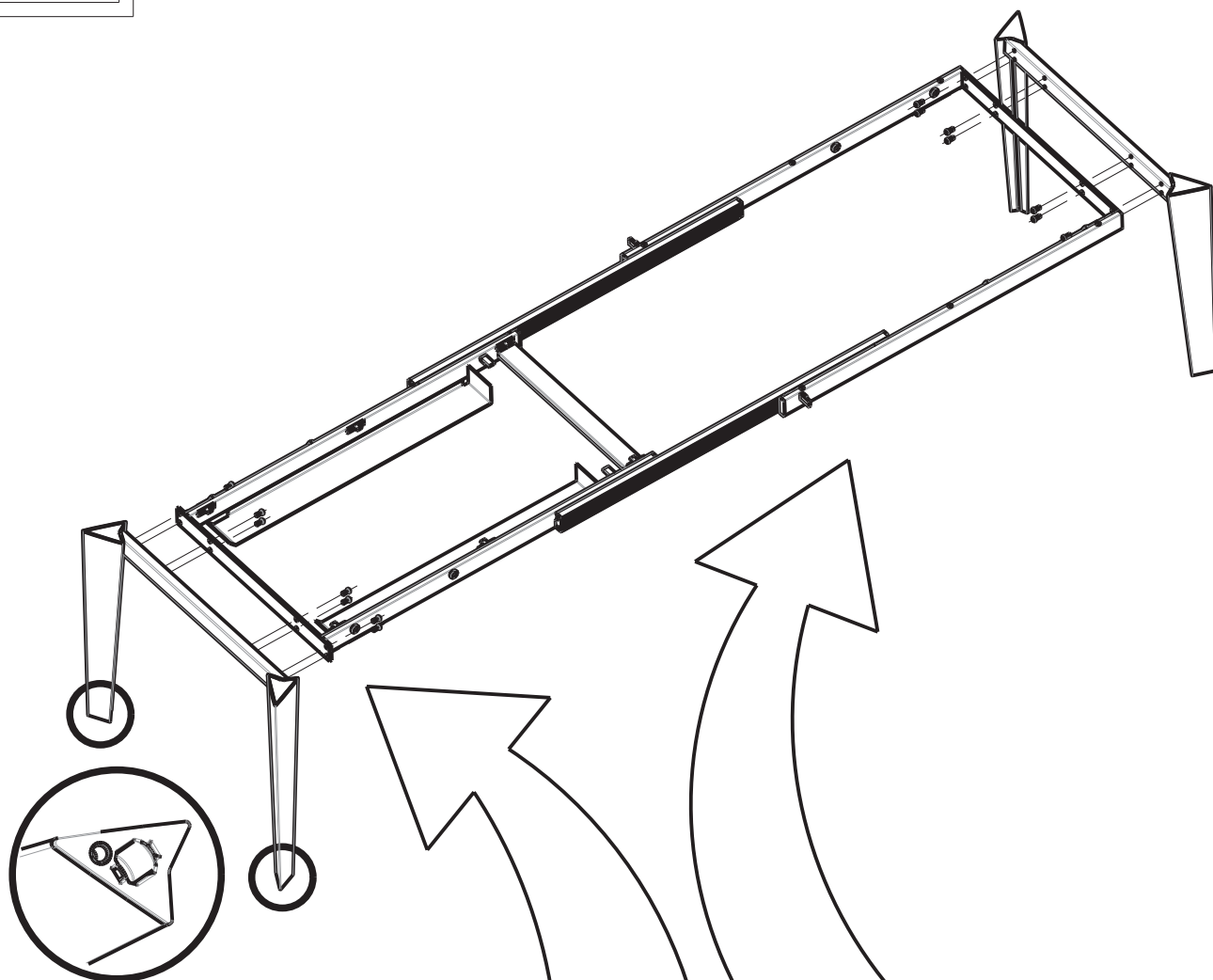

- Ⓛ GAMBA LATO PROLUNGA
- ⓐ EXTENSION SIDE LEG
- ⓓ FUß KANTE DER VERLÄNGERUNG
- ⓕ PIED CÔTÉ ALLONGE
- ⓔ PATA LADO PROLONGACIÓN
- ⓇⓈ НОГА СО СТОРОНЫ УДЛИНИТЕЛЯ

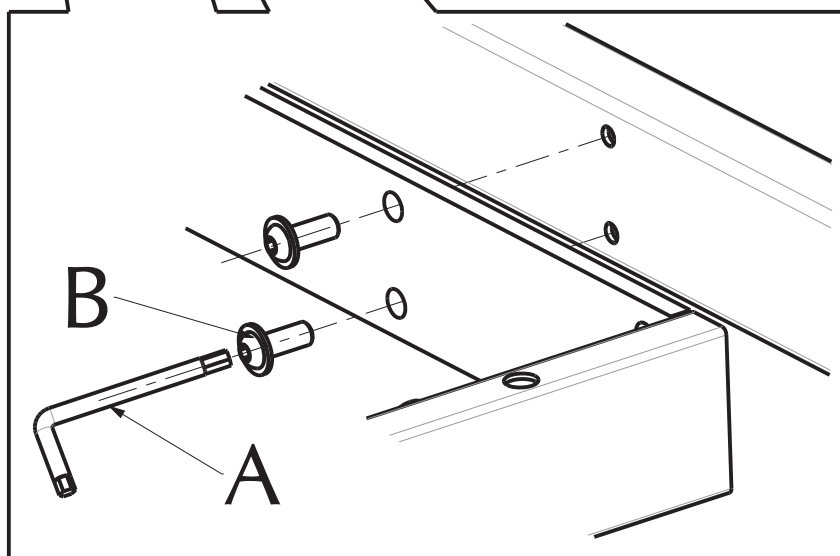

- (I) PIANO IN CRISTALLO / SUPERCERAMICA / SUPERMARMO / SUPERCEMENTO
- (GB) GLASS TOP / TOP IN SUPERCERAMIC / TOP IN SUPERMARBLE / TOP IN SUPERCONCRETE
- (D) GLASPLATTE / PLATTE SUPERKERAMIK / PLATTE SUPERMARMOR / PLATTE SUPERZEMENT
- (F) PLATEAUX EN VERRE / SUPERCERAMICA / SUPERMARBRE / SUPERBETON
- (E) SOBRE EN CRISTAL / SUPERCERAMICA / SUPERMÁRMOL / SUPERCEMENTO
- (RU) СТОЛЕШНИЦА ИЗ СТЕКЛА / СУПЕРКЕРАМИКИ / СУПЕРМАРАМОРА / СУПЕРЦЕМЕНТА

1

- (I) CHIUDERE IL TELAIO
- (GB) CLOSE THE FRAME
- (D) GESTELL SCHLIEßEN
- (F) FERMER LE CHÂSSIS
- (E) CERRAR LA ESTRUCTURA
- (RU) ЗАКРЫТЬ РАМУ

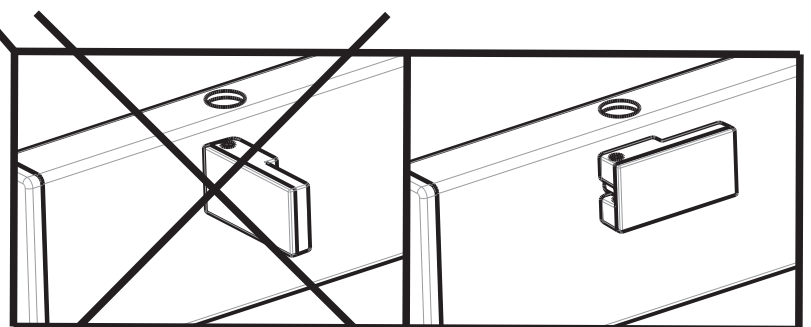
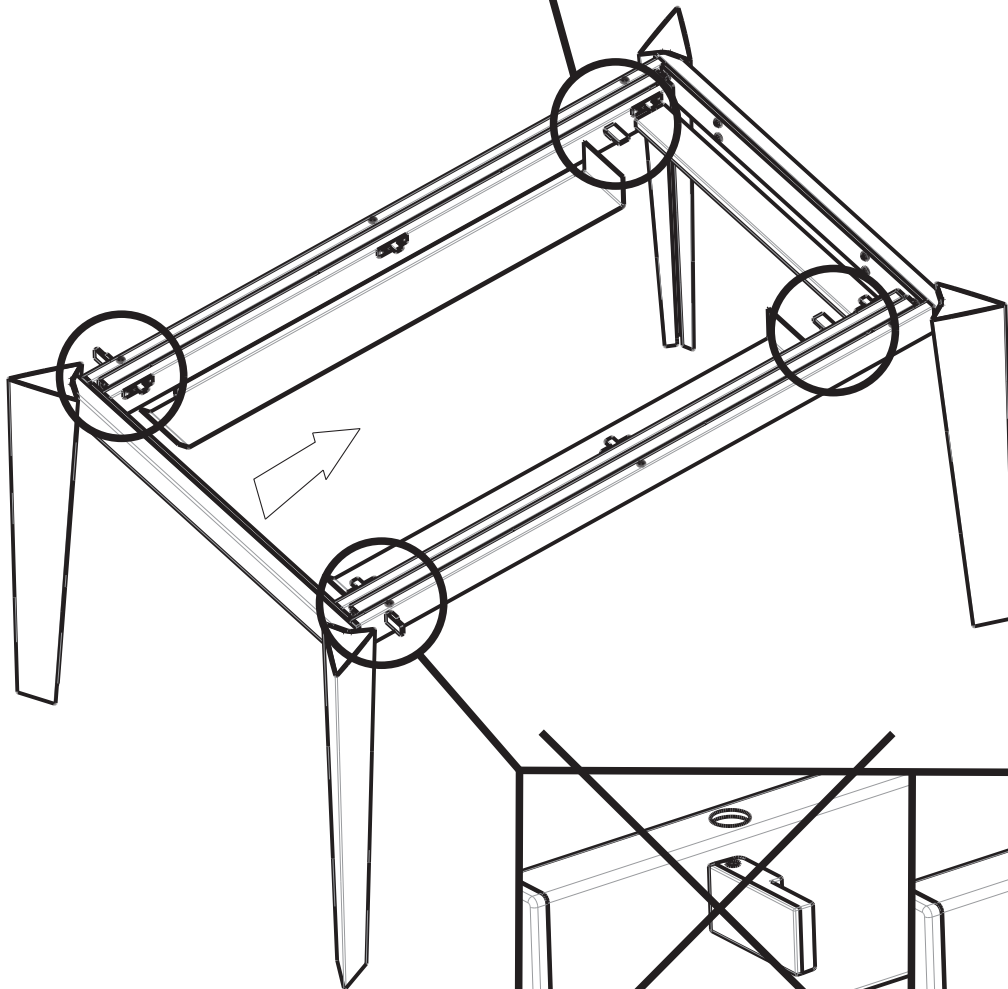
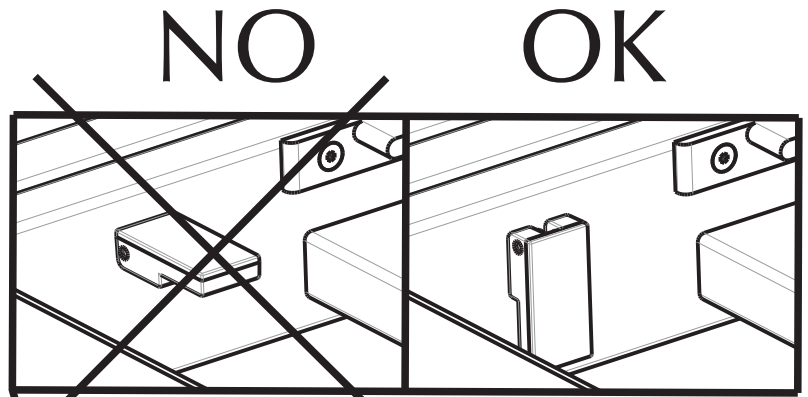

NO OK

2

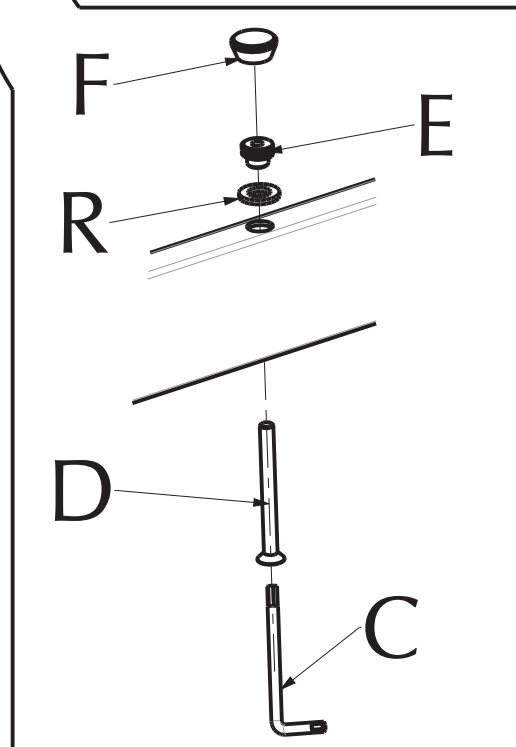
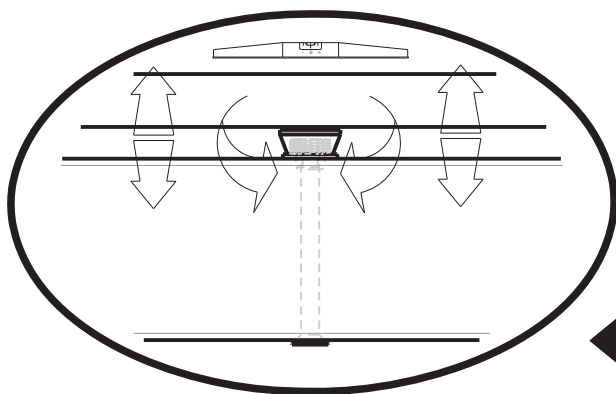
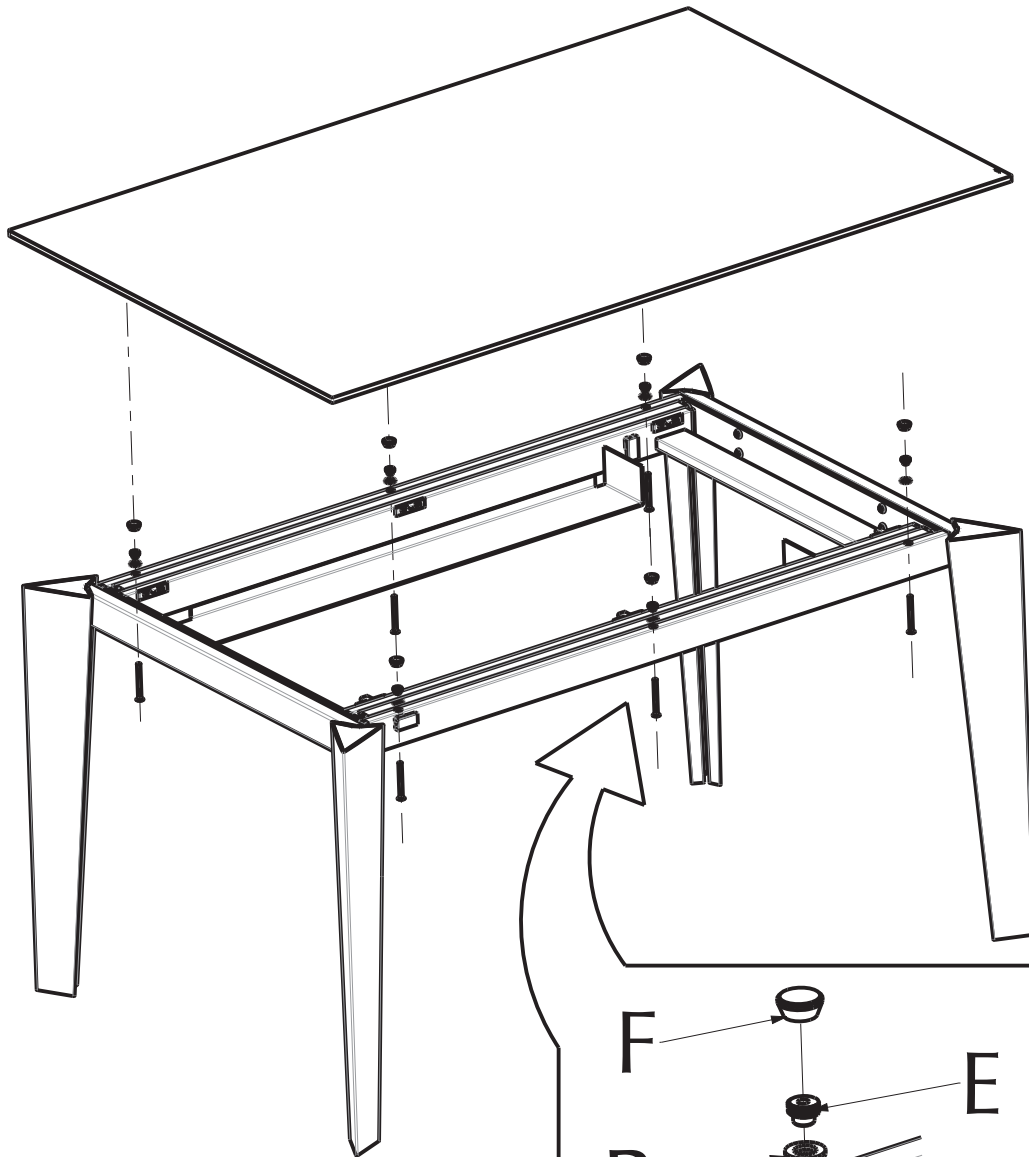

- (I) Ruotare il particolare (F) per regolare planarità e altezza del top
- (GB) Turn part (F) to adjust the heightband flatness top
- (D) Drehen Sie Teil (F), um die Höhe und Ebenheit oben anpassen
- (F) Tourner le particulier (F) pour ajuster la hauteur et la planéité du plateau
- (E) Girar la pieza (F) para ajustar la altura y la planitud del sobre
- (RU) Вращать деталь (F) для регулирования ровности и высоты столешницы

3

- ⓐ ALLUNGHE (a)
- ⓑ EXTENSIONS (a)
- ⓒ VERLÄNGERUNG (a)
- ⓓ ALLONGES (a)
- ⓔ PROLONGACIONES (a)
- ⓕ УДЛИНИТЕЛИ (a)

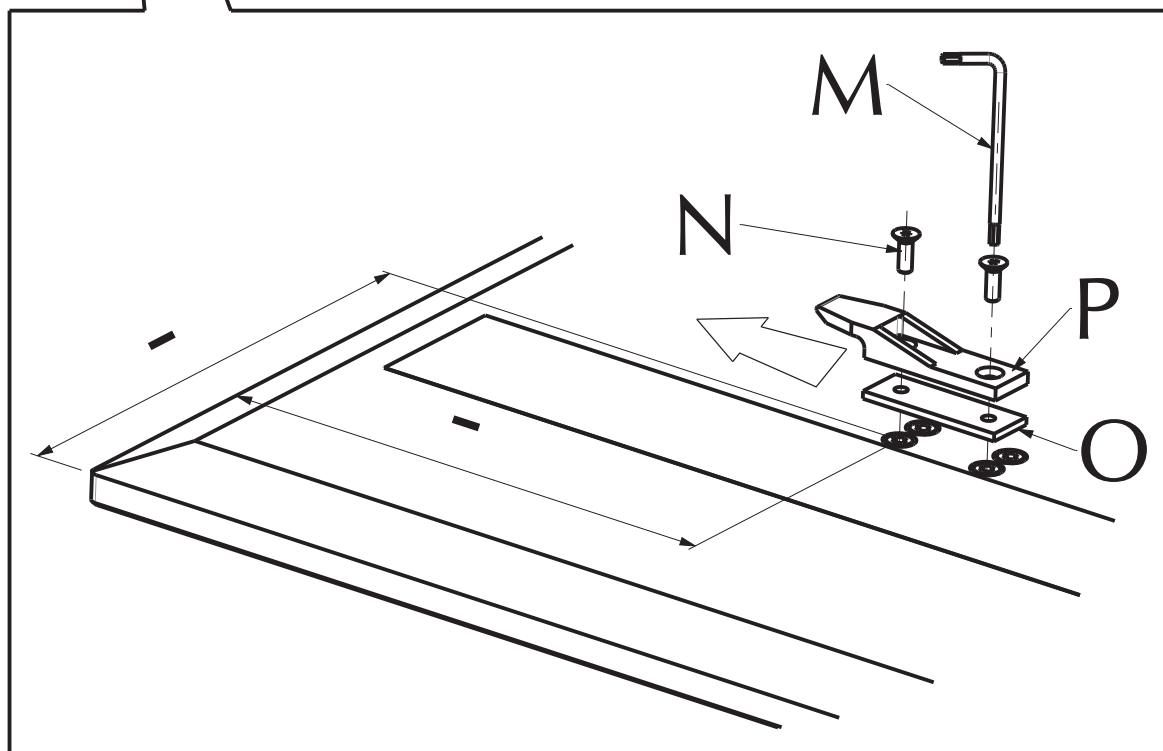
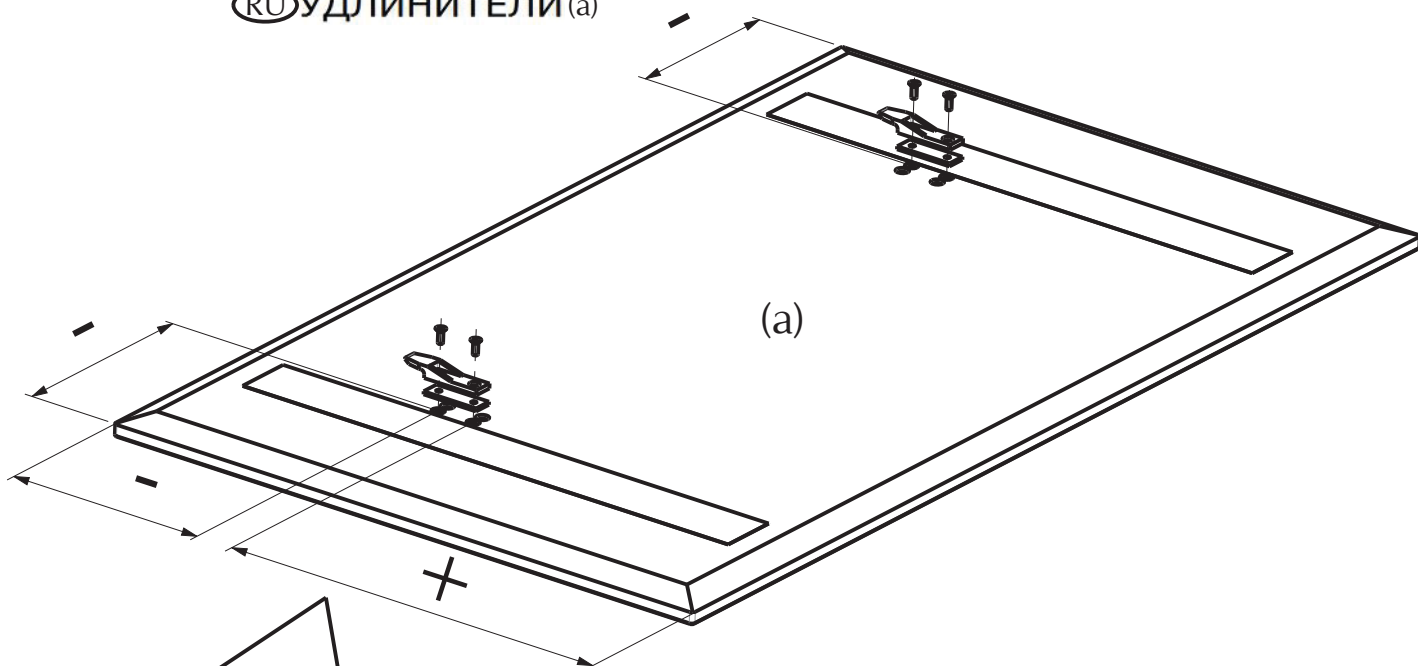

4

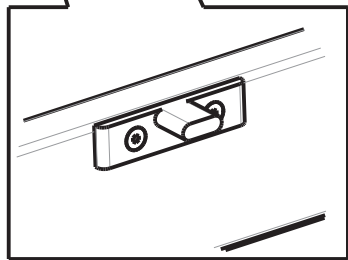
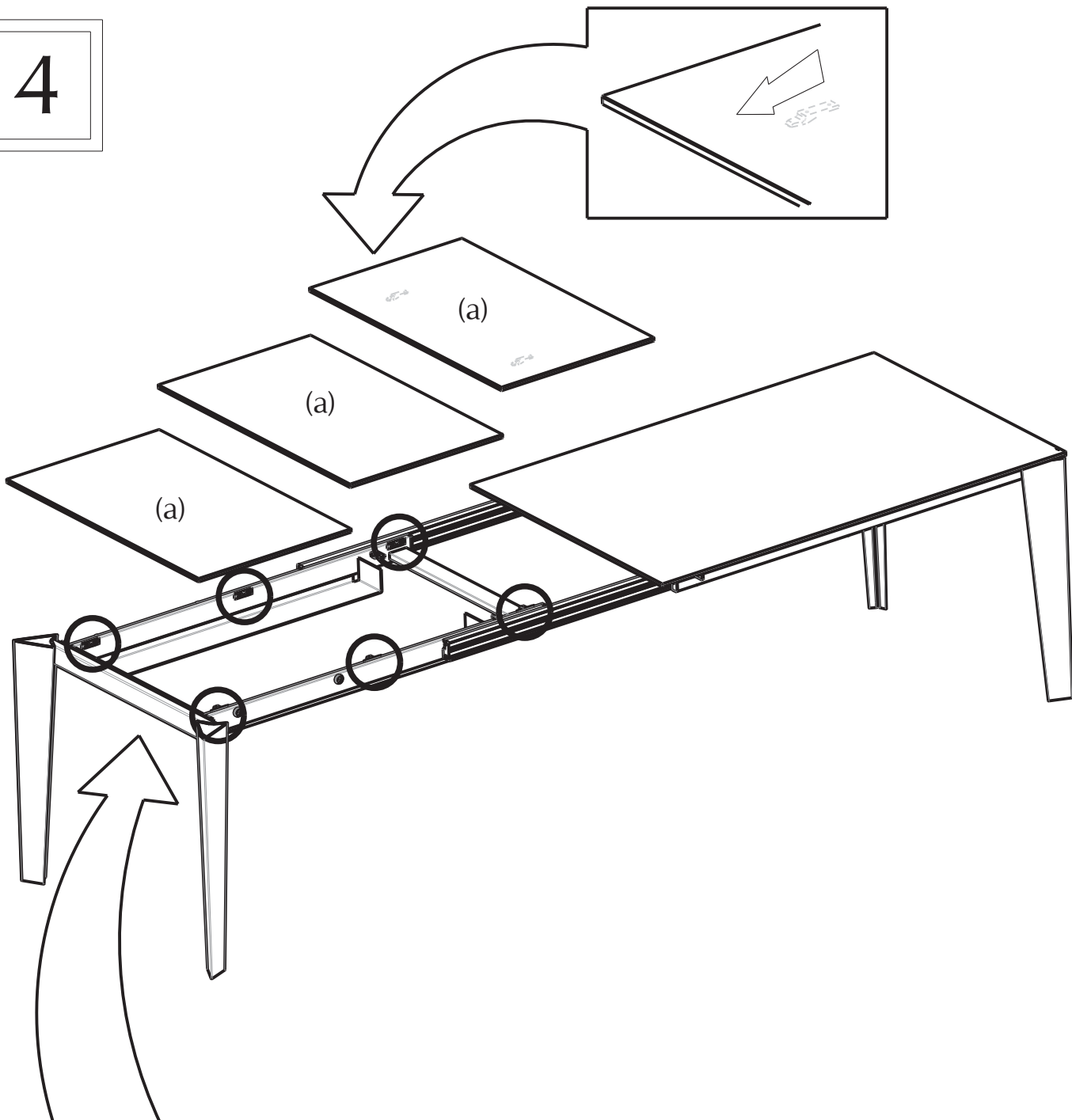

- ⓐ GAMBA LATO PROLUNGA (a)
- ⓐ EXTENSION SIDE LEG (a)
- ⓐ FUß KANTE DER VERLÄNGERUNG (a)
- ⓐ PIED CÔTÉ ALLONGE (a)
- ⓐ PATA LADO PROLONGACIÓN (a)
- ⓐ НОГА СО СТОРОНЫ УДЛИНИТЕЛЯ (a)

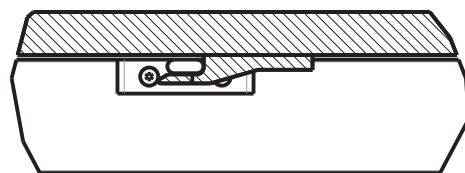
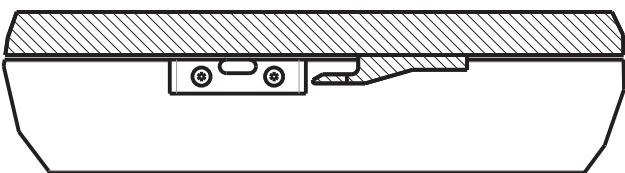

5

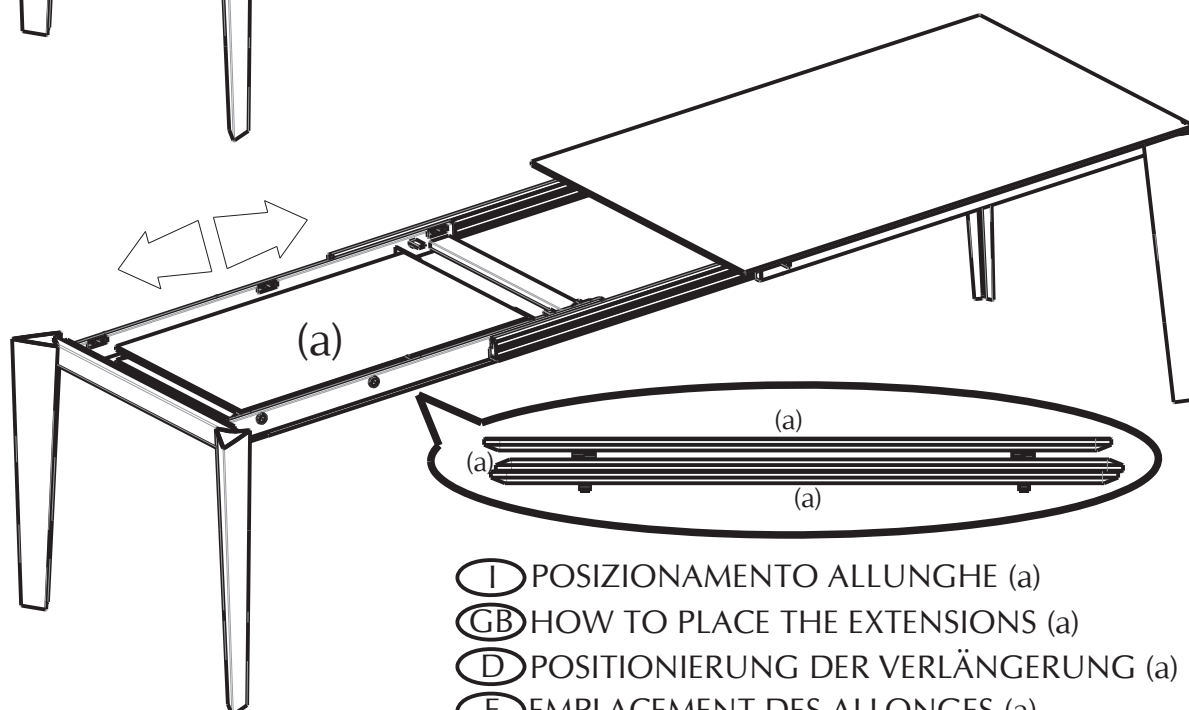
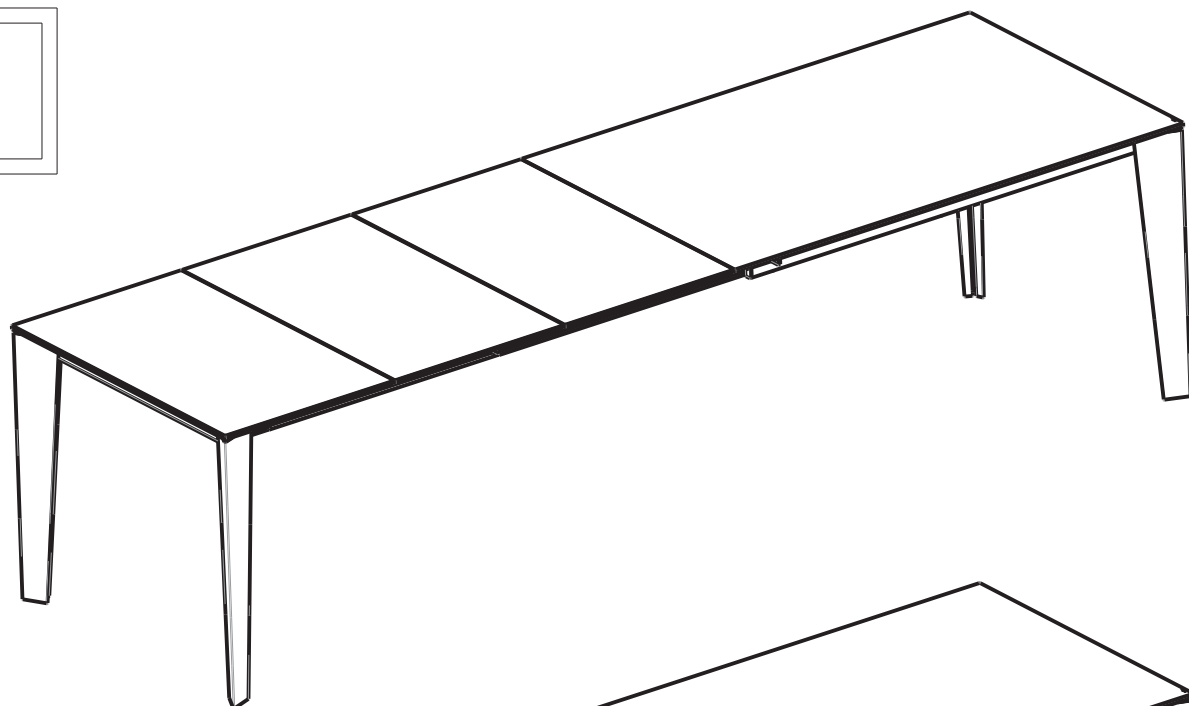

- Ⓘ POSIZIONAMENTO ALLUNGHE (a)
- Ⓒ HOW TO PLACE THE EXTENSIONS (a)
- Ⓓ POSITIONIERUNG DER VERLÄNGERUNG (a)
- Ⓕ EMBLACEMENT DES ALLONGES (a)
- Ⓔ COLOCACIÓN DE LAS PROLONGACIONES (a)
- ⒴ УСТАНОВКА УДЛИНИТЕЛЕЙ (a)

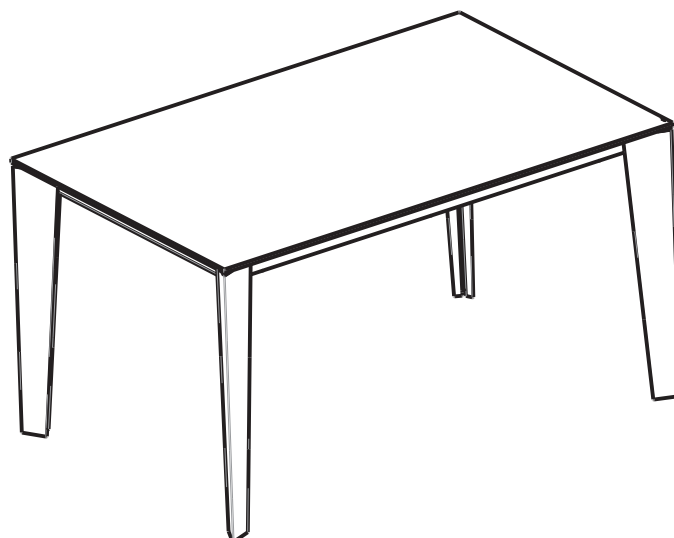

- (I) PIANI IMPIALLACCIATI / MELAMINICO / FENIX / UNICOLOR
- (GB) VENEERED / MELAMINE / FENIX / UNICOLOR TOPS
- (D) PLATTE FURNIERT / MELAMIN / FENIX / UNICOLOR
- (F) PLATEAUX EN BOIS PLAQUE / MELAMINE / FENIX / UNICOLOR
- (E) SOBRES EN CHAPEADOS / MELAMINADO / FENIX / UNICOLOR
- (RU) СТОЛЕШНИЦЫ ИЗ ШПОНА / МЕЛАМИНА / ФЕНИКСА / УНИКОЛОРА

1

- (I) CHIUDERE IL TELAIO
- (GB) CLOSE THE FRAME
- (D) GESTELL SCHLIEßEN
- (F) FERMER LE CHÂSSIS
- (E) CERRAR LA ESTRUCTURA
- (RU) ЗАКРЫТЬ РАМУ

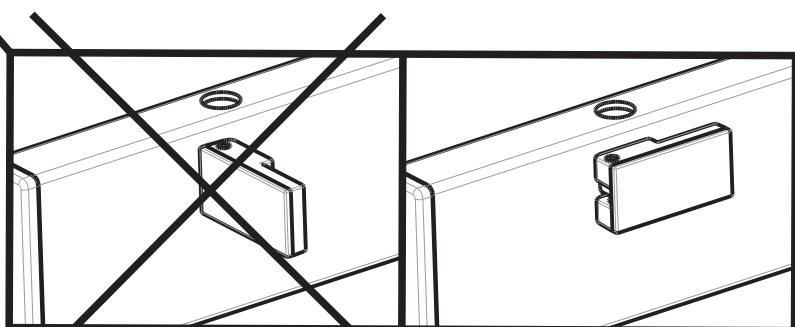
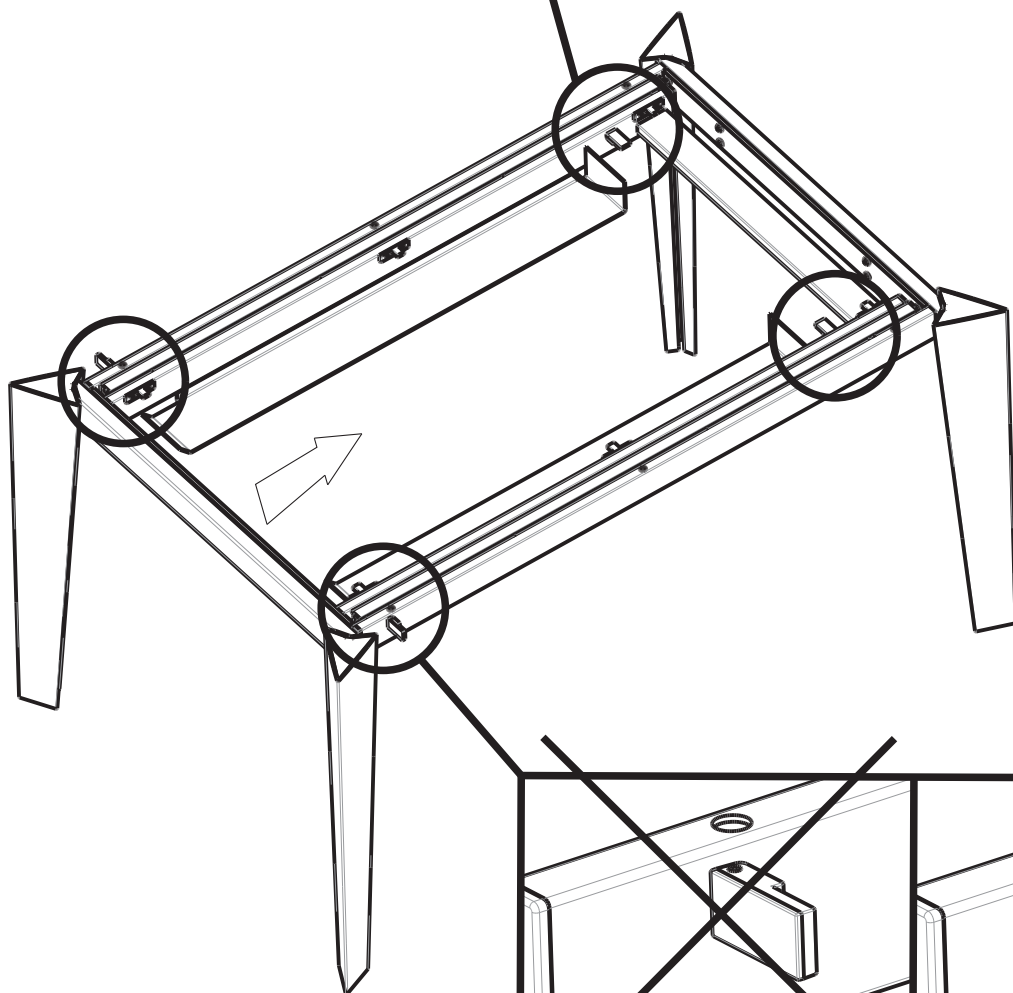
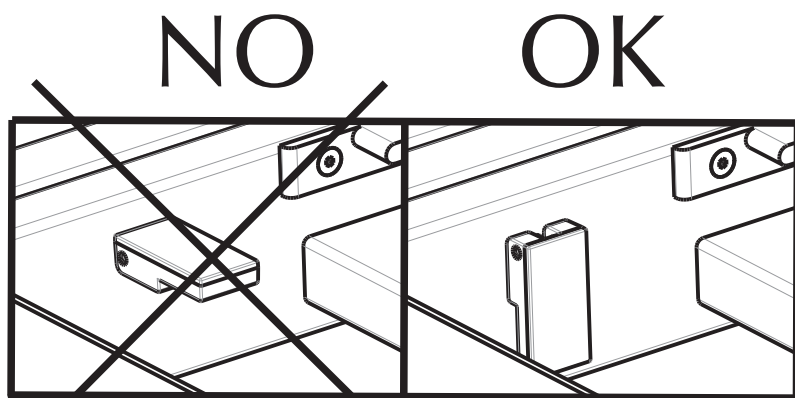

NO OK

2

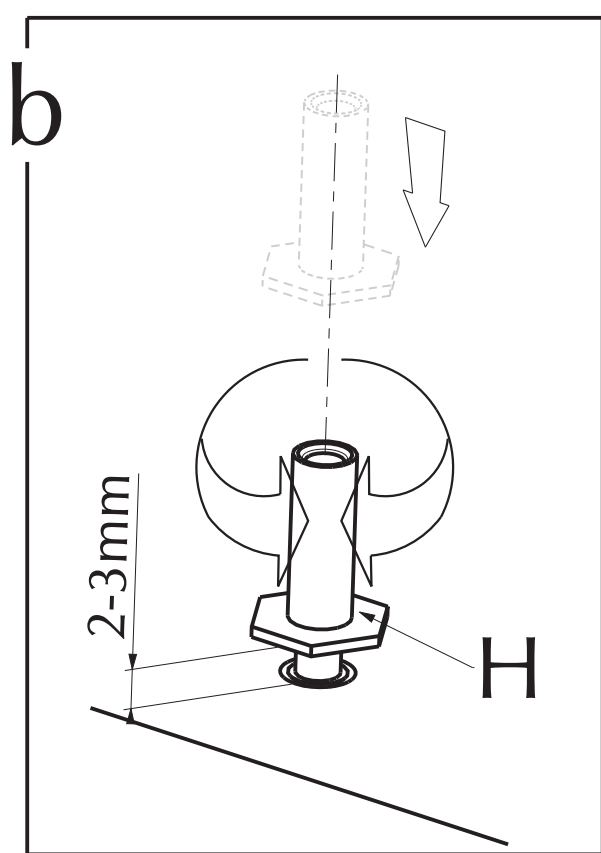
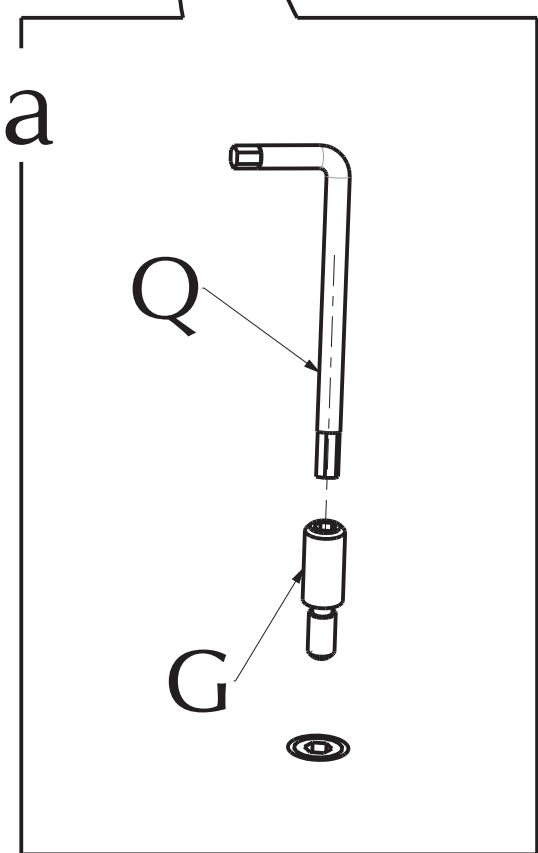
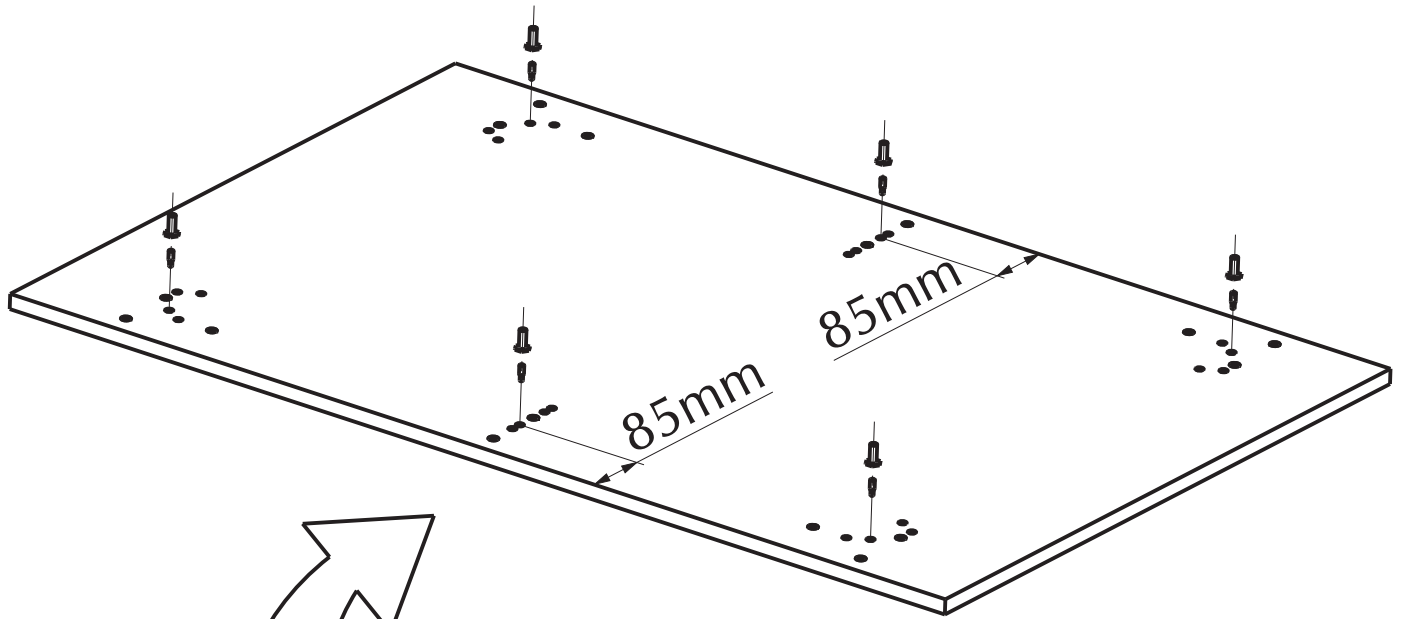

2

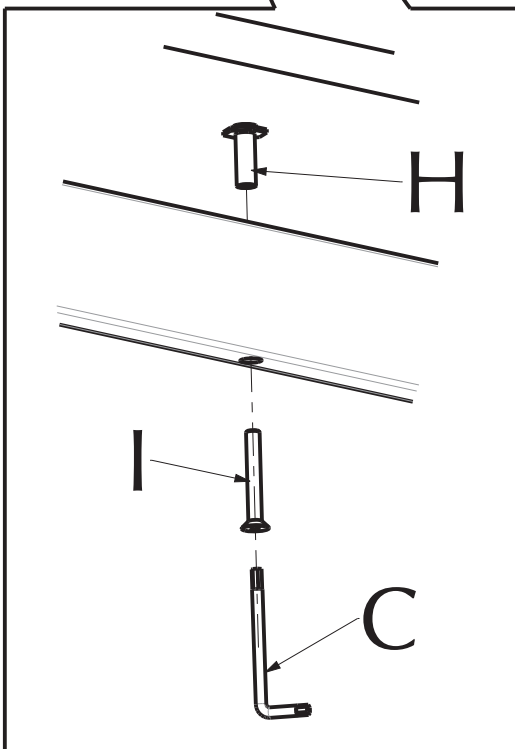
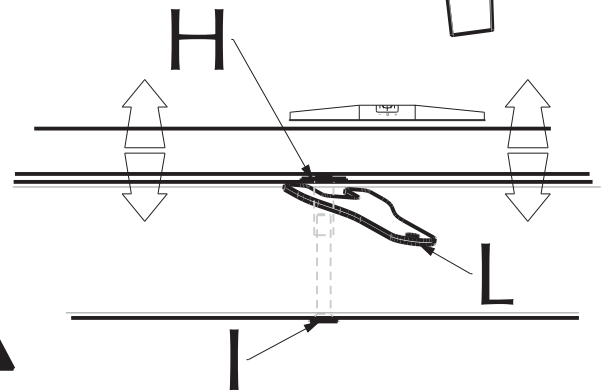
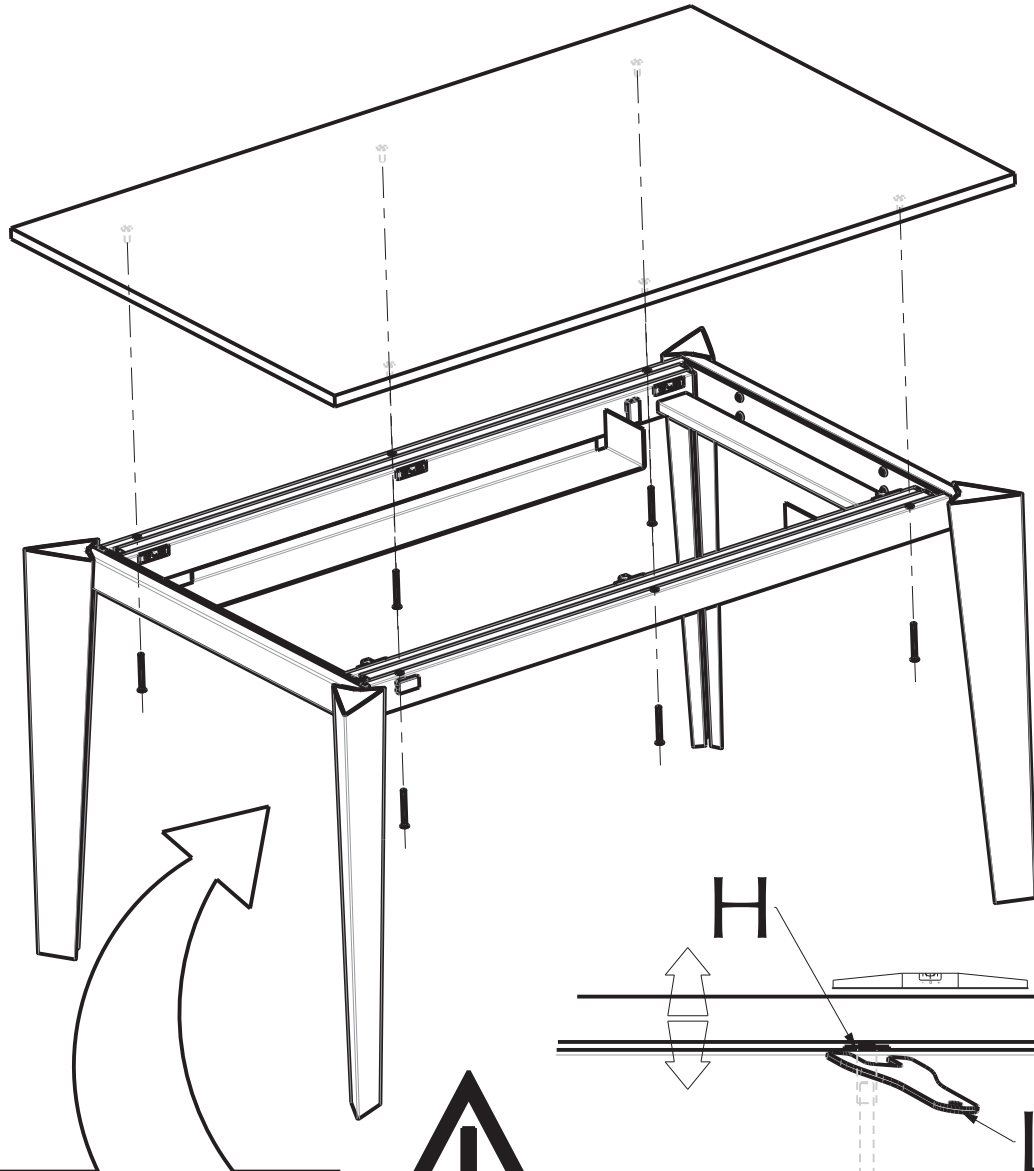

- (I) 1) inserire viti fissaggio (I) senza serrarle.
2) regolare in altezza il piano girando i cilindri di regolazione (H). Poi serrare le viti del piano (I).
- (GB) 1) Insert mounting screws (I) without tightening.
2) Adjust the height of the top by turning the adjusting cylinders (H). Then tighten the screws of the top (I).
- (D) 1) Die Befestigungsschrauben (I) legen ohne anziehen.
2) Die Höhe der Platte einstellen durch Drehen der Einstell-Zylinder (H). Dann die Schrauben der Platte (I) ziehen.
- (F) 1) insérer les vis de fixations (I) sans le serrer.
2) Régler en hauteur le plateau en tournant les vérins de réglage (H). Et après serrer les vis du plateau (I).
- (E) 1) inserir los tornillos (I) sin apretar.
2) Regular el sobre por medio de los cilindros de regulación (H). Luego apretar los tornillos del sobre (I).
- (RU) 1) ВСТАВИТЬ БОЛТЫ КРЕПЛЕНИЯ (I), НЕ ЗАТЯГИВАЯ ИХ.
2) РЕГУЛИРОВАТЬ ПО ВЫСОТЕ СТОЛЕШНИЦУ, ВРАЩАЯ ЦИЛИНДРЫ РЕГУЛИРОВКИ (H). ЗАТЕМ ЗАКРУТИТЬ ВИНТЫ СТОЛЕШНИЦЫ (I).

3

- ⓐ ALLUNGHE (a)
- ⓑ EXTENSIONS (a)
- ⓒ VERLÄNGERUNG (a)
- ⓓ ALLONGES (a)
- ⓔ PROLONGACIONES (a)
- ⓕ УДЛИНИТЕЛИ (a)

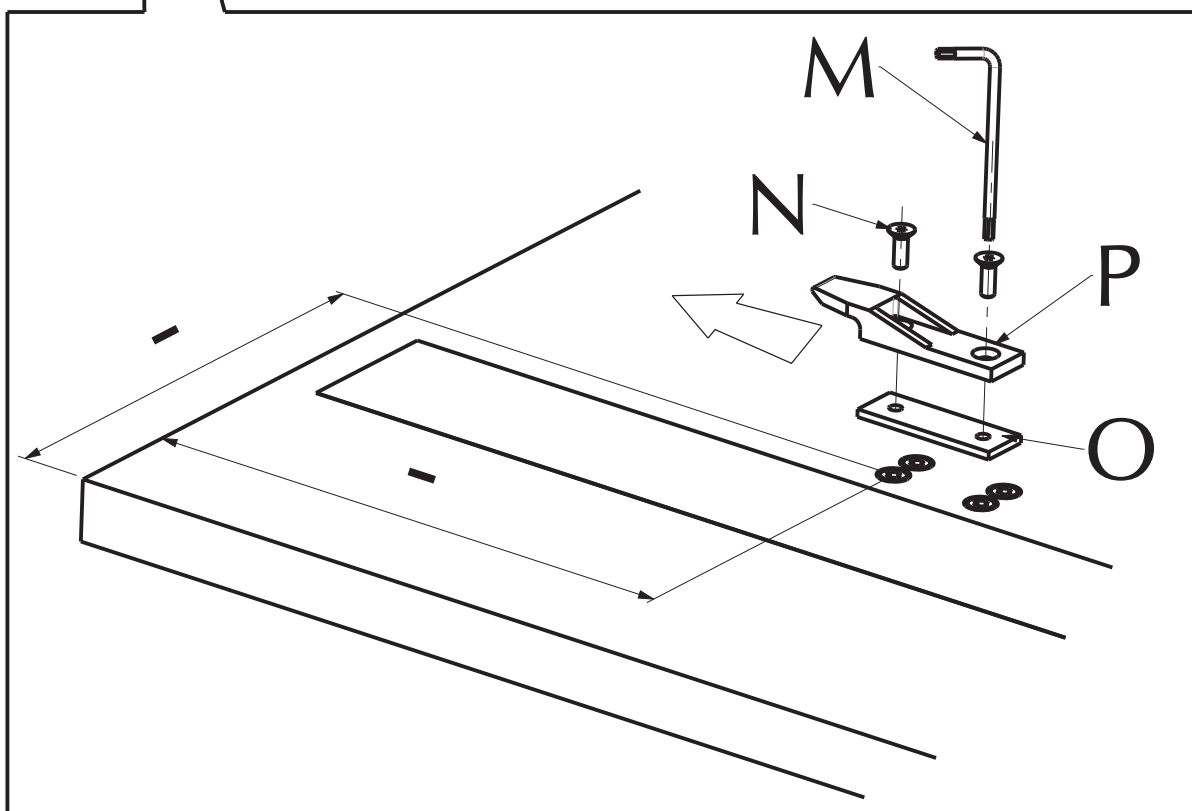
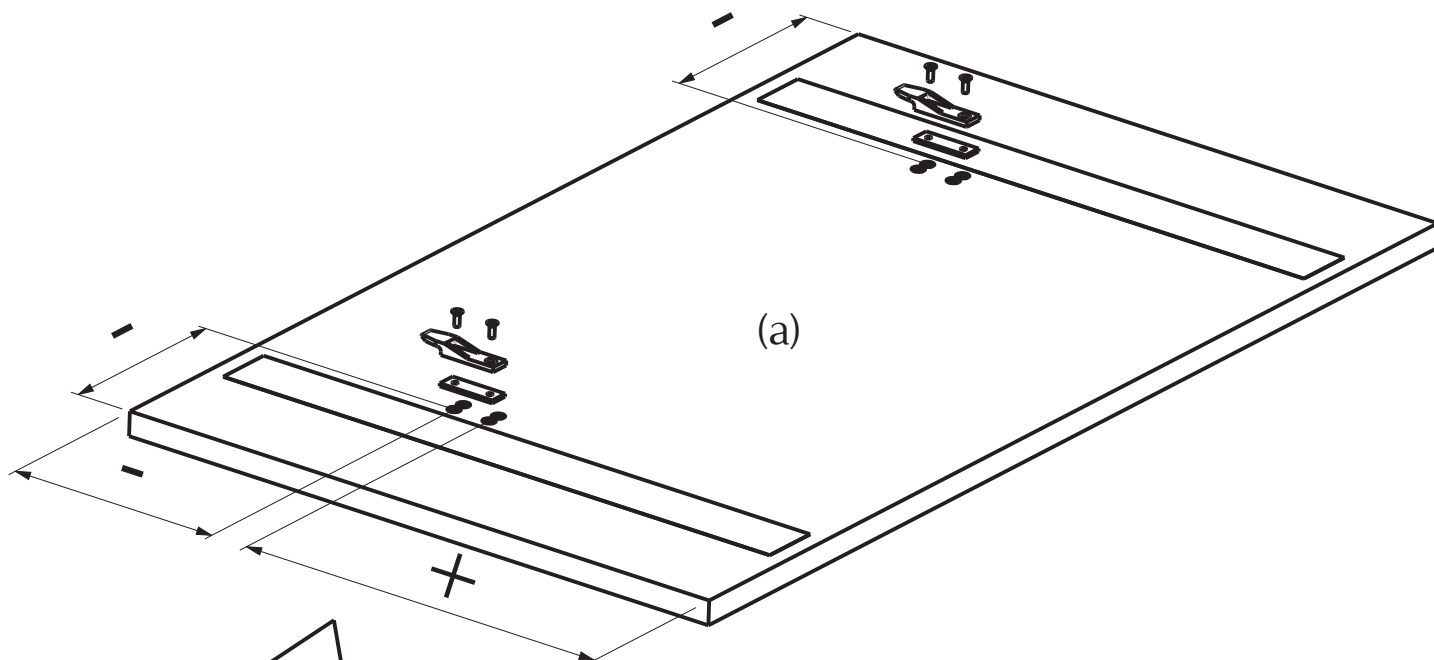

4

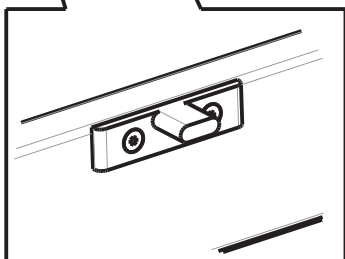
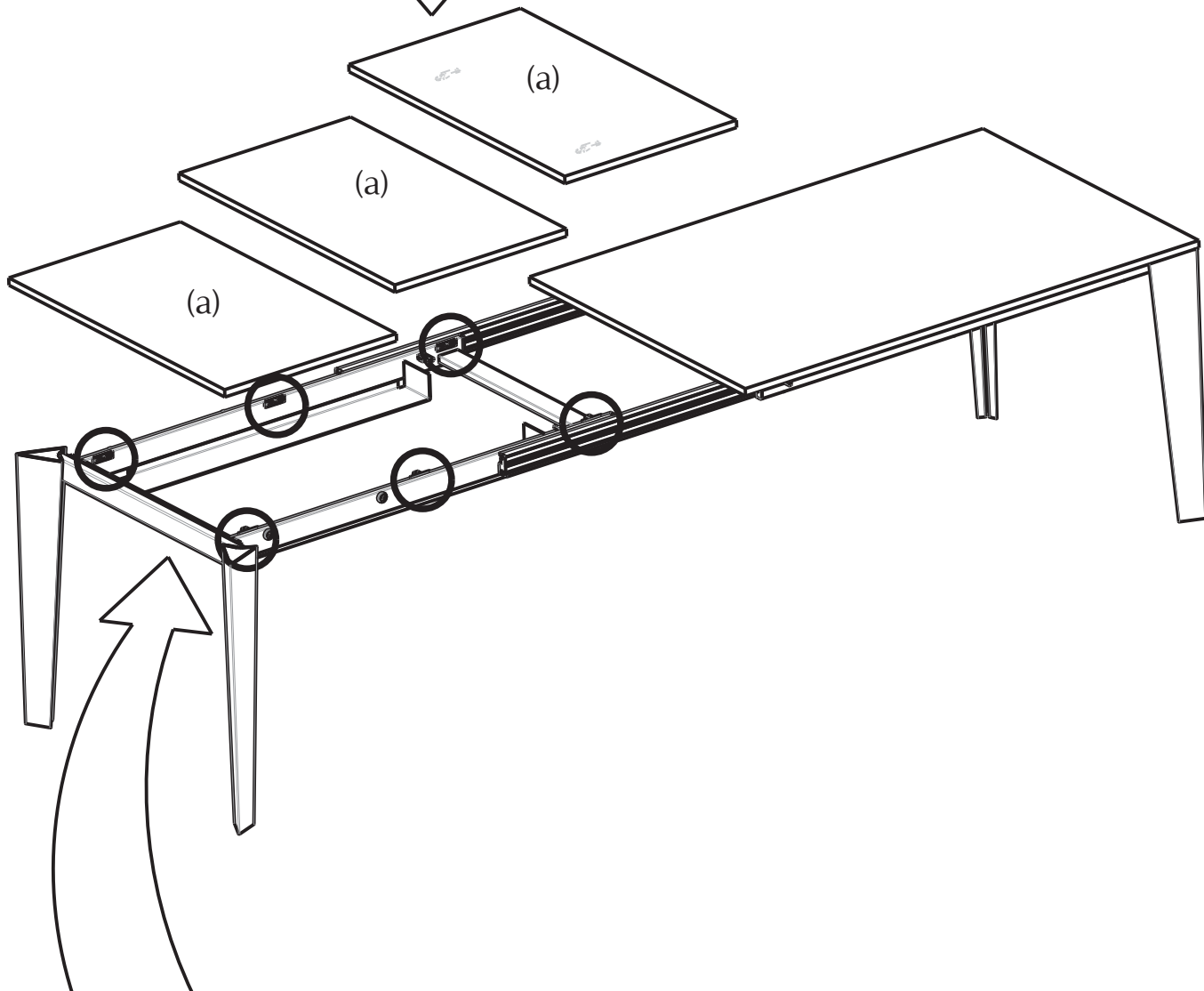
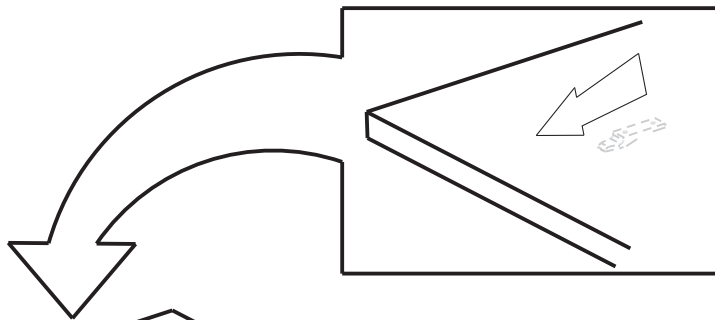

- ⓐ GAMBA LATO PROLUNGA (a)
- ⓑ EXTENSION SIDE LEG (a)
- ⓓ FUß KANTE DER VERLÄNGERUNG (a)
- ⓕ PIED CÔTÉ ALLONGE (a)
- ⓔ PATA LADO PROLONGACIÓN (a)
- ⓇⓊ НОГА СО СТОРОНЫ УДЛИНИТЕЛЯ (a)

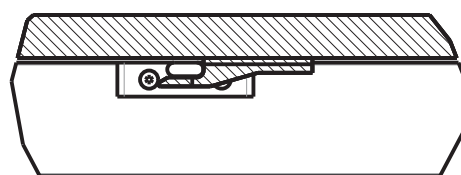
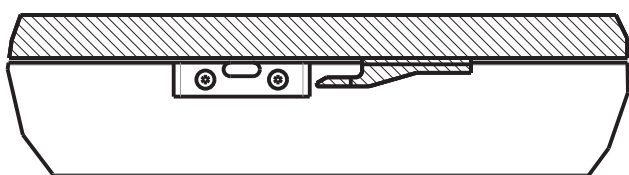

5

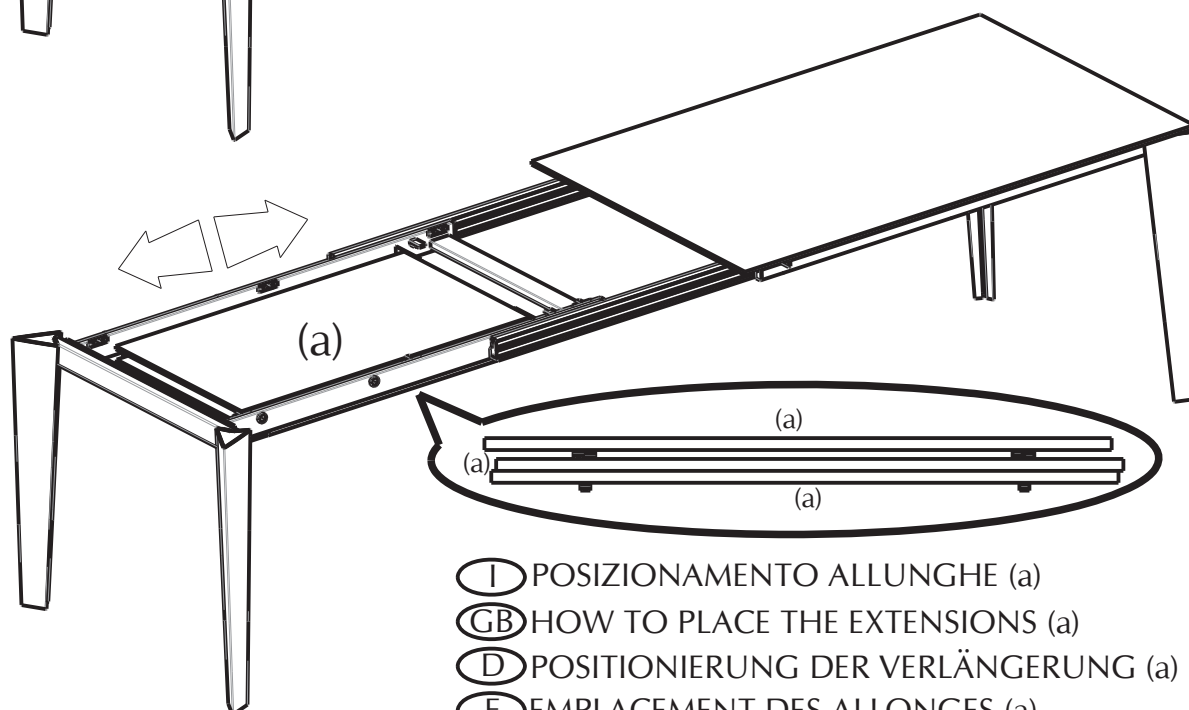
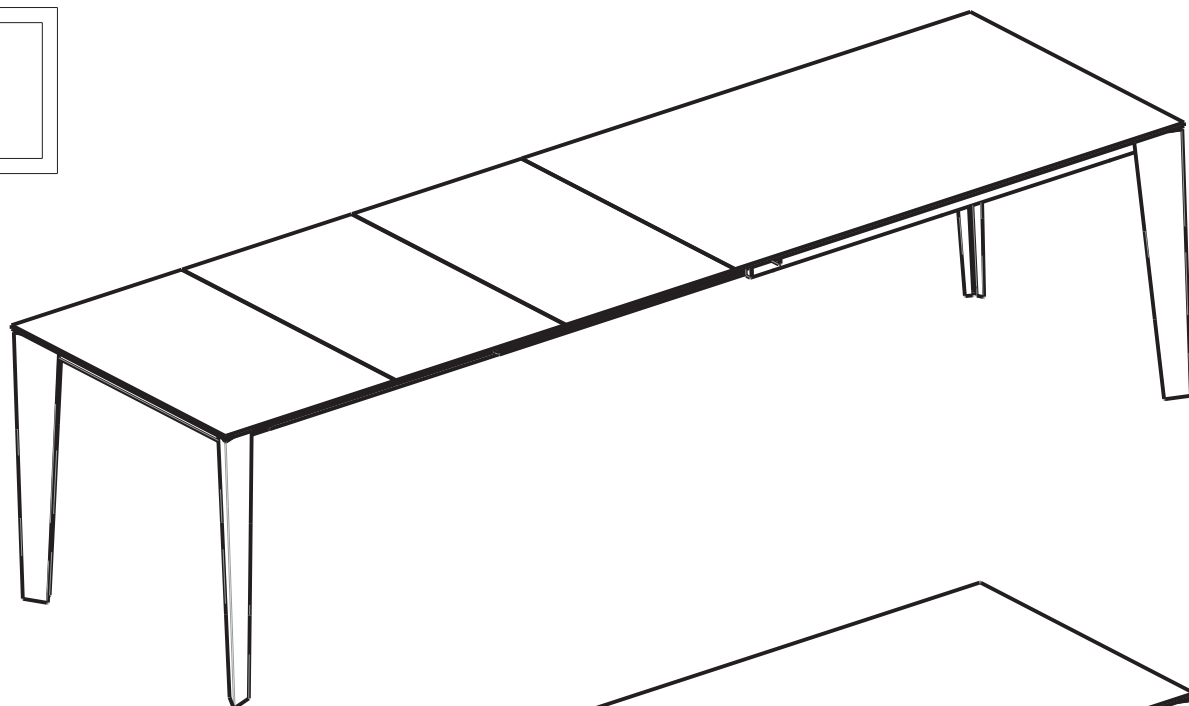

- Ⓘ POSIZIONAMENTO ALLUNGHE (a)
- Ⓒ HOW TO PLACE THE EXTENSIONS (a)
- Ⓓ POSITIONIERUNG DER VERLÄNGERUNG (a)
- Ⓕ EMBLACEMENT DES ALLONGES (a)
- Ⓔ COLOCACIÓN DE LAS PROLONGACIONES (a)
- Ⓔ УСТАНОВКА УДЛИНИТЕЛЕЙ (a)

